



Operation **Manual**

Goodrive300-01A Series VFD
for Air Compressor



SHENZHEN INVT ELECTRIC CO., LTD.

No.	Change description	Version	Release date
1	First release	V1.0	November 2020
2

Preface

Goodrive300-01A series variable-frequency drive (VFD) for air compressors (hereinafter referred to as GD300-01A VFD) is designed and developed by INVT based on the requirements of the air compressor industry, which can be applied in the control of synchronous/asynchronous air compressor. The product supports an optional multi-function expansion card, which is suitable for air compressor control that requires more functions.

Goodrive300-01A VFD carries the air compressor-specific control logic to connect to various signals of the air compressor directly e.g. emergency-stop, pressure and temperature signals, fan current transformer and fault signals. It can provide 24V power to HMI. It also carries RS485 communication interface of standard Modbus protocol to fit the HMI without external controller or PLC, simplifying the electrical design while realizing excellent variable-frequency control.

GD300-01A VFD has undergone compatibility test with multiple mainstream motor or master manufacturers based on the application features and actual needs of air compressor industry. It adopts dedicated PID and unique flux-weakening design to enable the air compressor to start quickly and run smoothly with max driving frequency reaching 400Hz. Through high-power density design and compact structure, it simplifies commissioning procedures and downgrades product size. It adopts independent air duct, heavy-load and high power factor design to cope with challenging field and grid environment.

Read this manual carefully before installation to ensure GD300-01A VFD can be installed and operated correctly to give full play to its excellent performance.

If the product is ultimately used for military affairs or weapon manufacture, comply with the export control regulations in the Foreign Trade Law of the People's Republic of China and complete related formalities.

Our company reserves the right to update the information of our products without prior notice.

Contents

Preface	i
Contents	ii
1 Safety precautions	1
1.1 What this chapter contains	1
1.2 Safety definition	1
1.3 Warning	1
1.4 Safety guidelines	1
1.4.1 Delivery and installation	2
1.4.2 Commissioning and running	3
1.4.3 Maintenance and component replacement	3
1.4.4 Scrap treatment	4
2 Product overview	5
2.1 Product specification	5
2.2 Product nameplate	7
2.3 Model description	7
2.4 Rated specifications	8
3 Wiring instruction	11
3.1 Main circuit wiring and terminal description	11
3.1.1 Main circuit wiring diagram	11
3.1.2 Main circuit terminal diagram	13
3.2 Control circuit wiring and terminal description	21
4 Commissioning instruction	25
4.1 Commissioning instruction for the dual-VFD air compressor	25
4.1.1 Wiring diagram of the dual-VFD air compressor system	25
4.1.2 Commissioning steps for the dual-VFD air compressor	25
4.2 Commissioning guidance for single-VFD air compressor	33
4.2.1 Wiring diagram for single-VFD air compressor system	33
4.2.2 Commissioning steps for single-VFD air compressor	33
5 Function description	35
5.1 Function parameter list	35
P00 group Basic functions	35
P01 group Start and stop control	37
P02 group Motor 1 parameters	39
P03 group Vector control	42
P04 group SVPWM control	46
P05 group Input terminals	47
P06 group Output terminals	51
P07 group HMI	55

P08 group Enhanced functions	61
P09 group PID control.....	66
P11 group Protection parameters.....	69
P13 group Synchronous motor control parameters.....	71
P14 group Serial communication	73
P17 group Status viewing	74
P18 group Functions for air compressors	77
P19 group Air compressor status viewing	84
P20 group Function for water lubrication.....	90
P21 group Power-frequency fan protection.....	91
P25 group Fault policy	93
5.2 Control logic of the air compressor.....	96
5.3 Fault policy function description	98
6 Fault information and fault handling	102
6.1 VFD faults and solutions	102
6.2 Fault contents and solutions of air compressor equipment	106
Appendix A Product dimensions	111
A.1 Keypad diagram.....	111
A.2 External keypad installation dimensions	111
A.3 Wall installation dimensions of 380V–440V VFDs	112
A.4 Flange installation dimensions of 380V–440V VFDs	115
A.5 Wall installation dimensions of 520V–690V VFDs	117
A.6 Flange installation dimensions of 520V–690V VFDs	118
A.7 Floor installation dimensions of 520V–690V VFDs	119
A.8 Product weight and package dimensions of 380V–440V VFDs	120
A.9 Product weight and package dimensions of 520V–660V VFDs	121
Appendix B External optional accessories	122
B.1 Multi-function expansion card EC-IO304	122
B.1.1 Brief introduction.....	122
B.1.2 Assembly instruction	124
B.2 RS485 communication LCD keypad	127
B.2.1 LCD keypad introduction.....	127
B.2.2 LCD keypad structure	130
B.2.3 RS485 communication cable	130
B.2.4 Setting parameters on the LCD keypad.....	131
B.2.5 Fault records.....	151
B.2.6 VFD information.....	153
B.2.7 System configuration	154
B.3 HMI touch screen.....	161
B.3.1 Specifications.....	161

B.3.2 Connection terminals	163
B.3.3 Wiring description	164
B.3.4 Cable description	164
B.3.5 Installation dimensions and description	165
B.4 Filter	166
B.5 Reactor	167
Appendix C Current transformer of the fan	168
C.1 Current transformer model selection.....	168
C.2 Wiring of current transformer of the fan	168
C.3 Parameter setup of current transformer of the fan	169
Appendix D Communication protocol	170
D.1 Application mode	170
D.2 RTU command code and communication data	170
Appendix E Common EMC problems and troubleshooting.....	177
E.1 Interference problems of meter switches and sensors.....	177
E.2 485 communication interferences	177
E.3 Unstoppable or shimmering indicator caused by coupling of motor cable	178
E.4 Leakage current and residual current device (RCD)	179
E.5 Problem of charged device shell	180

1 Safety precautions

1.1 What this chapter contains

Read this manual carefully and follow all safety precautions before moving, installing, operating and servicing the product. Otherwise, equipment damage or physical injury or death may be caused.

We shall not be liable or responsible for any equipment damage or physical injury or death caused due to your or your customers' failure to follow the safety precautions.

1.2 Safety definition

Danger: Severe personal injury or even death can result if related requirements are not followed.









Warning: Personal injury or equipment damage can result if related requirements are not followed.

Note: Actions taken to ensure proper running.

Trained and qualified professionals: People operating the equipment must have received professional electrical and safety training and obtained the certificates, and must be familiar with all steps and requirements of equipment installing, commissioning, running and maintaining and capable to prevent any emergencies.



1.3 Warning

Warnings caution you about conditions that can result in severe injury or death and/or equipment damage and advice on how to prevent dangers. The following table lists the warning symbols in this manual.

Symbol	Name	Description	Abbreviation
 Danger	Danger	Severe personal injury or even death can result if related requirements are not followed.	
 Warning	Warning	Personal injury or equipment damage can result if related requirements are not followed.	
 Forbid	Electrostatic discharge	PCBA board damage can result if related requirements are not followed..	
 Hot sides	Note Hot sides	The equipment base may become hot. Do not touch it.	
Note	Note	Actions taken to ensure proper running.	Note

1.4 Safety guidelines

	◇ Only trained and qualified professionals are allowed to carry out related operations.
---	---

	<p>◇ Do not perform wiring, inspection or component replacement when power supply is applied. Ensure that all the input power supplies are disconnected before wiring and inspection, and always wait for at least the time designated on the VFD or until the DC bus voltage is less than 36V. The waiting time is shown as below.</p> <table border="1" data-bbox="292 328 934 563"> <thead> <tr> <th colspan="2">VFD model</th> <th>Minimum waiting time</th> </tr> </thead> <tbody> <tr> <td>380V</td> <td>7.5kW-110kW</td> <td>5 minutes</td> </tr> <tr> <td>380V</td> <td>132kW-315kW</td> <td>15 minutes</td> </tr> <tr> <td>380V</td> <td>Higher than 350kW</td> <td>25 minutes</td> </tr> <tr> <td>660V</td> <td>22kW-132kW</td> <td>5 minutes</td> </tr> <tr> <td>660V</td> <td>160kW-350kW</td> <td>15 minutes</td> </tr> <tr> <td>660V</td> <td>400kW-630kW</td> <td>25 minutes</td> </tr> </tbody> </table>	VFD model		Minimum waiting time	380V	7.5kW-110kW	5 minutes	380V	132kW-315kW	15 minutes	380V	Higher than 350kW	25 minutes	660V	22kW-132kW	5 minutes	660V	160kW-350kW	15 minutes	660V	400kW-630kW	25 minutes
VFD model		Minimum waiting time																				
380V	7.5kW-110kW	5 minutes																				
380V	132kW-315kW	15 minutes																				
380V	Higher than 350kW	25 minutes																				
660V	22kW-132kW	5 minutes																				
660V	160kW-350kW	15 minutes																				
660V	400kW-630kW	25 minutes																				
	<p>◇ Do not refit the VFD unless authorized; otherwise fire, electric shock or other injury may result.</p>																					
	<p>◇ The base of the radiator may become hot during running. Do not touch to avoid hurt.</p>																					
	<p>◇ The electrical parts and components inside the VFD are electrostatic sensitive. Take measurements to prevent electrostatic discharge when performing related operations.</p>																					

1.4.1 Delivery and installation

	<ul style="list-style-type: none"> ◇ Do not install the VFD on inflammables. In addition, prevent the VFD from contacting or adhering to inflammables. ◇ Connect the optional brake parts (brake resistors, brake units or feedback units) according to the wiring diagram. ◇ Do not operate on the VFD if there is any damage or components loss to the VFD. ◇ Do not touch the VFD with wet items or body; otherwise, electric shock may occur.
--	---

Note:

- ◇ Select appropriate moving and installing tools to ensure a safe and normal running of the VFD and avoid physical injury or death. To ensure personal safety, the installer must take mechanical protective measures, such as wearing exposure shoes and working uniforms.
- ◇ Ensure the VFD suffers no physical impact or vibration during moving and installation.
- ◇ Do not carry the VFD by its front cover only as the cover may fall off.
- ◇ Installation site must be away from children and other public places.
- ◇ The application environment should be proper and appropriate.

- ◇ Prevent the screws, cables and other conductive objects from falling into the VFD.
- ◇ The leakage current of the VFD may be above 3.5mA during operation. Ground with proper techniques and ensure the grounding resistor is less than 10Ω. The conductivity of PE grounding conductor is the same as that of the phase conductor (with the same cross sectional area). For models of higher than 30 kW, the cross sectional area of the PE grounding conductor can be slightly less than the recommended area.
- ◇ R, S and T are the power supply input terminals, while U, V and W are the output motor terminals. Connect the input power cables and motor cables correctly; otherwise, damage to the VFD may occur.

1.4.2 Commissioning and running

	<ul style="list-style-type: none"> ◇ Disconnect all power supplies of the VFD before terminal wiring and wait for at least the designated time after disconnecting the power supply. ◇ High voltage is present inside the VFD during running. Do not carry out any operation on the VFD except for keypad setting. ◇ The VFD may start up by itself when P01.21=1. Do not get close to the VFD and motor. ◇ The VFD cannot be used as "Emergency-stop device". ◇ The VFD cannot be used to brake the motor suddenly. A mechanical brake device must be installed.
---	--

Note:

- ◇ Do not switch on or off the input power supply of the VFD frequently.
- ◇ For VFDs that have been stored for a long time, check and fix the capacitance and try pilot run first before actual application.
- ◇ Close the front cover before running the VFD; otherwise, electric shock may occur.

1.4.3 Maintenance and component replacement

	<ul style="list-style-type: none"> ◇ Only well-trained and qualified professionals are allowed to carry out maintenance, inspection, and component replacement of the VFD. ◇ Disconnect all power supplies of the VFD before terminal wiring and wait for at least the designated time after disconnecting the power supply. ◇ Take proper measures to prevent screws, cables and other conductive objects from falling into the VFD during maintenance and component replacement. During maintenance and component replacement, take measures to prevent screws, cables and other conductive matters from falling into the internal of the programmable controller.
---	---



Note:

- ◇ Use proper torque to tighten screws.
- ◇ Keep the VFD and its parts and components away from combustible materials during

maintenance and component replacement.

- ◇ Do not carry out any insulation voltage-endurance test on the VFD or measure the control circuit of the VFD by megameter.
- ◇ Take anti-static measures on the VFD and internal parts during maintenance and component replacement.

1.4.4 Scrap treatment

	◇ There are heavy metals in the VFD. Treat with it as industrial effluent.
	◇ When the life cycle ends, the product should enter the recycling system. Dispose of it separately at an appropriate collection point instead of placing it in the normal waste stream.

2 Product overview

2.1 Product specification

Category	Function	Specification
Power input	Input voltage of the VFD (V)	3PH 220V (-15%)–240V (+10%); Rated voltage: 220V 3PH 380V (-15%)–440V (+10%); Rated voltage: 380V 3PH 520V (-15%)–690V (+10%); Rated voltage: 660V
	Rated input current (A)	Refer to section 2.4 "Rated specifications".
	Rated input frequency (Hz)	50Hz or 60Hz; allowed range: 47–63Hz
	Efficiency	> 97%
Power output	Output voltage (V)	Equal to input voltage, error ratio: less than 5%
	Rated output current (A)	Refer to section 2.4 "Rated specifications".
	Rated output power (kW)	Refer to section 2.4 "Rated specifications".
	Output frequency (Hz)	0–400Hz
Low voltage DC power supply output	+24V DC power	24W (rated value: 24V/1A)
Running control performance	Control mode	Open loop vector, SVPWM
	Speed ratio	Asynchronous motor: 1:200 (SVC); Synchronous motor: 1:200 (SVC)
	Speed control precision	±0.2% (SVC)
	Speed fluctuation	±0.3% (SVC)
	Torque response	<20ms (SVC)
	Starting torque	Asynchronous motor: 0.25Hz 150% (SVC) Synchronous motor: 2.5Hz 150% (SVC)
	Frequency reference mode	PID control, Modbus communication, P1- and P2- analog input, keypad digital input
	Overload capacity	1min at 150%
	Analog pressure input	1 input (standard): P1+/P1- 1 input (optional): P2+/P2- 4–20mA/0–1.6MPa input

Category	Function	Specification
	Analog temperature input	1 input (standard): PTA1/PTB1 1 input (optional): PTA2/PTB2 Resolution: 1°C Range: -20°C~150°C Accuracy error: 3°C
	Analog output	1 output (standard): AO1/GND 0-10V/0-20mA
	Digital input	3 inputs (standard): S1, S2, S3 5 inputs (optional): S4, S5, S6, S7, S8 Common terminal: COM Max. frequency: 1kHz
	Digital output	2 outputs (standard): RO1A/RO1C, RO2A/RO2B/RO2C 4 inputs (optional): RO3A, RO4A, RO5A, RO6A, ROC Contact capacity: 3A/AC250V, 1A/DC30V
	485 communication	1 channel (standard): 485+/485- Shielding layer grounding PE/CGND
Others	Installation mode	Wall installation, flange installation
	Temperature of running environment	-10~+50°C; derating is required if the ambient temperature exceeds 40°C; derate by 1% for every increased 1°C
	Ingress protection rating	IP20
	Pollution degree	Degree 2
	Cooling mode	Forced air cooling
	DC reactor	DC reactors are optional parts for 7.5-11kW VFD models and can be built into the models; DC reactors have been built into 15-110kW VFD models as standard configuration; DC reactors are optional parts for 132-315kW VFD models (AC 380V) and can be externally connected.
	EMC filter	C3 filters have been built into the VFDs as standard configuration. ECM filter is set to be invalid by default, if it is necessary to enable it, you can manually plug the jumper cap in the socket marked J10.

2.2 Product nameplate

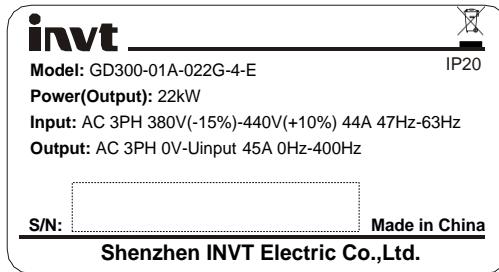

Figure 2-1 Product nameplate

Note: This is a nameplate example of a standard model. CE, TUV, KC, and IP20 are marked according to the actual certification condition.

2.3 Model description

The model code contains product information. Users can find the model code on the VFD nameplate or simple nameplate.

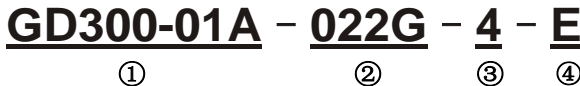

Figure 2-2 Product model

Table 2-1 Model description

Field	Symbol	Description	Content
Abbreviation of product series	①	Abbreviation of product series	Goodrive300-01A: GD300-01A VFD for air compressor
Rated power + Load type	②	Power class + Load type	022: 22kW G: Constant torque load
Voltage class	③	Voltage class	2: AC 3PH 220V(-15%)–240V(+10%) 4: AC 3PH 380V(-15%)–440V(+10%) 6: AC 3PH 520V(-15%)–690V(+10%)
Expandability	④	Optional multi-function expansion card	E: Optional multi-function expansion card EC-IO304

2.4 Rated specifications

Rated values of AC 3PH 220V(-15%)–240V(+10%) VFDs

Product model	Output power (kW)	Input current (A)	Output current (A)	Structural installation dimensions
GD300-01A-7R5G-2-E	7.5	32	30	Same with GD300-01A-015G-4-E
GD300-01A-011G-2-E	11	44	42	Same with GD300-01A-022G-4-E
GD300-01A-015G-2-E	15	58	55	Same with GD300-01A-030G-4-E
GD300-01A-018G-2-E	18.5	72	70	Same with GD300-01A-037G-4-E
GD300-01A-022G-2-E	22	87	80	Same with GD300-01A-045G-4-E
GD300-01A-030G-2-E	30	106	110	Same with GD300-01A-055G-4-E
GD300-01A-037G-2-E	37	140	130	Same with GD300-01A-075G-4-E
GD300-01A-045G-2-E	45	170	160	Same with GD300-01A-090G-4-E
GD300-01A-055G-2-E	55	202	200	Same with GD300-01A-110G-4-E
GD300-01A-075G-2-E	75	310	270	Same with GD300-01A-160G-4-E
GD300-01A-090G-2-E	90	345	320	Same with GD300-01A-185G-4-E
GD300-01A-110G-2-E	110	385	380	Same with GD300-01A-200G-4-E
GD300-01A-132G-2-E	132	485	450	Same with GD300-01A-250G-4-E
GD300-01A-160G-2-E	160	545	540	Same with GD300-01A-280G-4-E
GD300-01A-185G-2-E	185	610	620	Same with GD300-01A-315G-4-E

Rated values of AC 3PH 380V(-15%)–240V(+10%) VFDs

Model	Output power (kW)	Input current (A)	Output current (A)
GD300-01A-7R5G-4-E	7.5	25	18.5
GD300-01A-011G-4-E	11	32	25
GD300-01A-015G-4-E	15	32	32
GD300-01A-018G-4-E	18.5	37	38
GD300-01A-022G-4-E	22	44	45
GD300-01A-030G-4-E	30	58	60
GD300-01A-037G-4-E	37	72	75
GD300-01A-045G-4-E	45	87	92
GD300-01A-055G-4-E	55	106	115
GD300-01A-075G-4-E	75	140	150
GD300-01A-090G-4-E	90	170	180
GD300-01A-110G-4-E	110	202	215
GD300-01A-132G-4-E	132	265	260
GD300-01A-160G-4-E	160	310	305
GD300-01A-185G-4-E	185	345	340
GD300-01A-200G-4-E	200	385	380
GD300-01A-220G-4-E	220	430	425
GD300-01A-250G-4-E	250	485	480
GD300-01A-280G-4-E	280	545	530
GD300-01A-315G-4-E	315	610	600
GD300-01A-350G-4-E	350	625	650
GD300-01A-400G-4-E	400	715	720
GD300-01A-500G-4-E	500	890	860

Note:

- ◇ Rated input current is the actually measured result under 380V input voltage. Input current of 7.5–11kW and 132–315kW VFD models is the actually measured results in cases where there is no DC reactor. Input current of 15–110kW VFD models is the actually measured result in cases where there is DC reactor. Input current of 350–500kW VFD models is the actually measured result under 380V input voltage with input reactor.
- ◇ Rated output current is defined as the output current under 380V output voltage.
- ◇ Under the allowable input voltage range, the output current shall not exceed its rated output current, and the output power also shall not exceed its rated output power.

Rated values of AC 3PH 520V(-15%)–690V(+10%) VFDs

Model	Output power (kW)	Input current (A)	Output current (A)
GD300-01A-022G-6-E	22	35	27
GD300-01A-030G-6-E	30	40	35
GD300-01A-037G-6-E	37	47	45
GD300-01A-045G-6-E	45	52	52
GD300-01A-055G-6-E	55	65	62
GD300-01A-075G-6-E	75	85	86
GD300-01A-090G-6-E	90	95	98
GD300-01A-110G-6-E	110	118	120
GD300-01A-132G-6-E	132	145	150
GD300-01A-160G-6-E	160	165	175
GD300-01A-185G-6-E	185	190	200
GD300-01A-200G-6-E	200	210	220
GD300-01A-220G-6-E	220	230	240
GD300-01A-250G-6-E	250	255	270
GD300-01A-280G-6-E	280	286	300
GD300-01A-315G-6-E	315	334	350
GD300-01A-350G-6-E	350	360	380
GD300-01A-400G-6-E	400	411	430
GD300-01A-500G-6-E	500	518	540
GD300-01A-560G-6-E	560	578	600
GD300-01A-630G-6-E	630	655	680

Note:

- ✧ Input current of 22–350kW VFD models is the actually measured result under 660V input voltage without DC reactor and input/output reactor.
- ✧ Input current of 400–630kW VFD models is the actually measured result under 660V input voltage with input reactor.
- ✧ Rated output current is defined as the output current under 660V output voltage.
- ✧ Under the allowable input voltage range, the output current shall not exceed its rated output current, and the output power also shall not exceed its rated output power.

3 Wiring instruction

3.1 Main circuit wiring and terminal description

3.1.1 Main circuit wiring diagram

For VFDs of AC 3PH 380V (-15%)–440V (+10%)

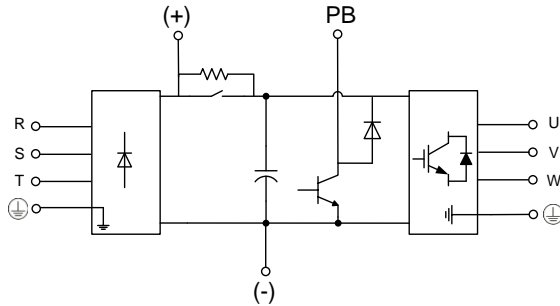

Figure 3-1 Main circuit wiring diagram for 7.5kW VFD models

Note: DC reactors are optional parts for 7.5kW VFD models and can be built into the models.

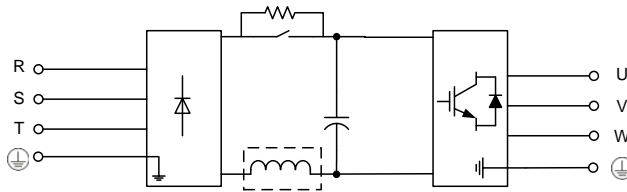

Figure 3-2 Main circuit wiring diagram for 11–15kW VFD models

Note: DC reactors are optional parts for 11kW VFD models and can be built into the models. DC reactors have been built into 15kW VFD models as standard configuration.

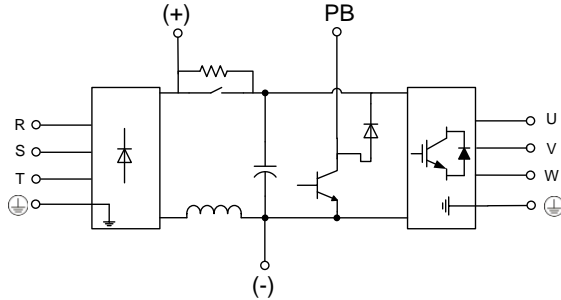

Figure 3-3 Main circuit wiring diagram for 18.5–110kW VFD models

Note: DC reactors have been built into 18.5–110kW VFD models as standard configuration.

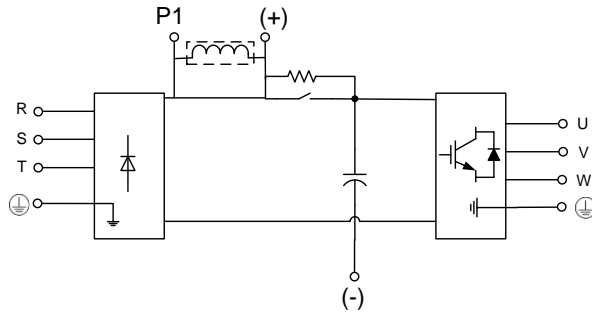

Figure 3-4 Main circuit wiring diagram for 132–500kW VFD models

Note: DC reactors are optional parts for 132–500kW VFD models and can be externally connected.

For VFDs of AC 3PH 520V (-15%)–690V (+10%)

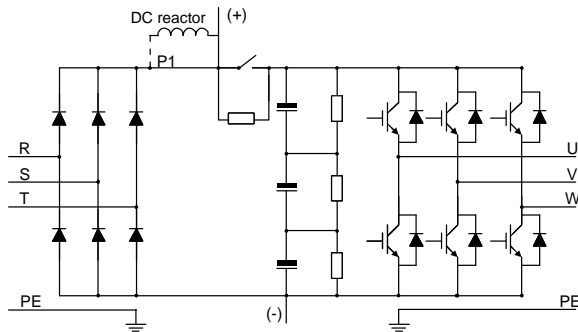

Figure 3-5 Main circuit schematic diagram for 660V VFD models

The 660V series VFDs can be connected to external DC reactors. Before connection, remove the

copper bar between P1 and (+). DC reactors are optional parts.

3.1.2 Main circuit terminal diagram

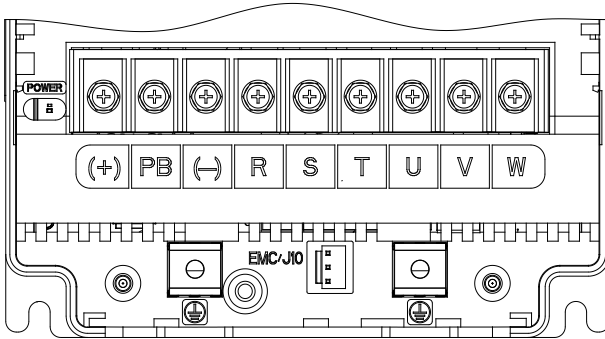

Figure 3-6 Main circuit terminal diagram for 380V 7.5kW VFD models

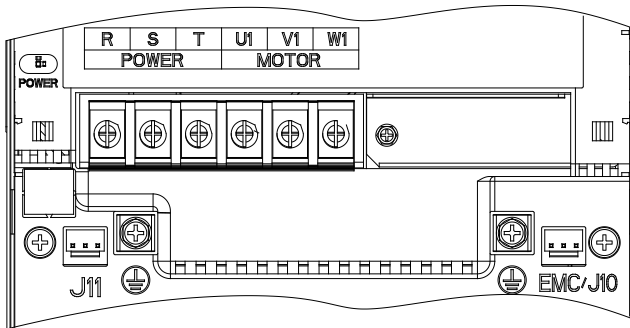

Figure 3-7 Main circuit terminal diagram for 380V 11-15kW VFD models

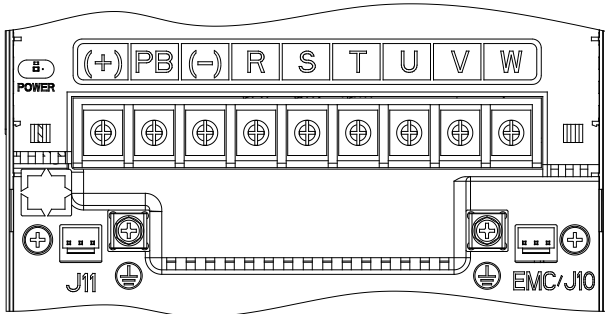

Figure 3-8 Main circuit terminal diagram for 380V 18.5-22kW VFD models

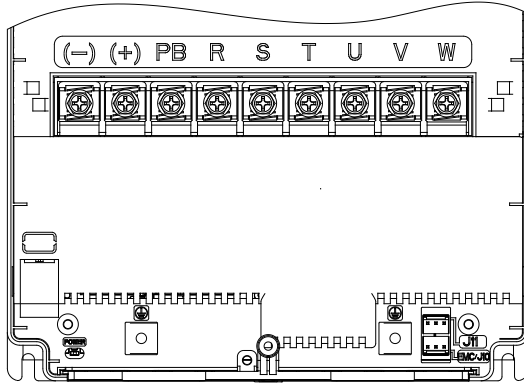

Figure 3-9 Main circuit terminal diagram for 380V 30–37kW VFD models

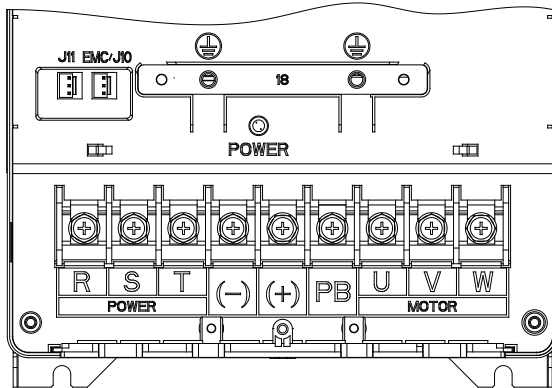

Figure 3-10 Main circuit terminal diagram for 380V 45–55kW VFD models

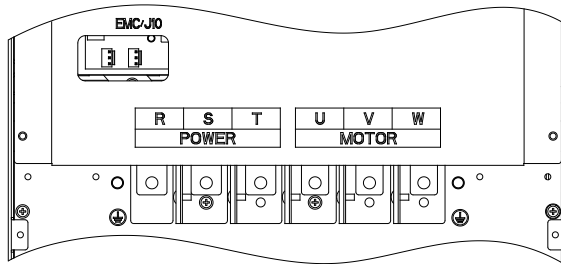

Figure 3-11 Main circuit terminal diagram for 380V 75kW VFD models

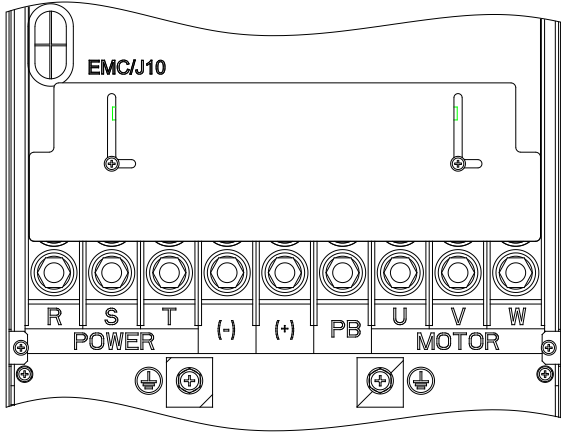

Figure 3-12 Main circuit terminal diagram for 380V 90-110kW VFD models

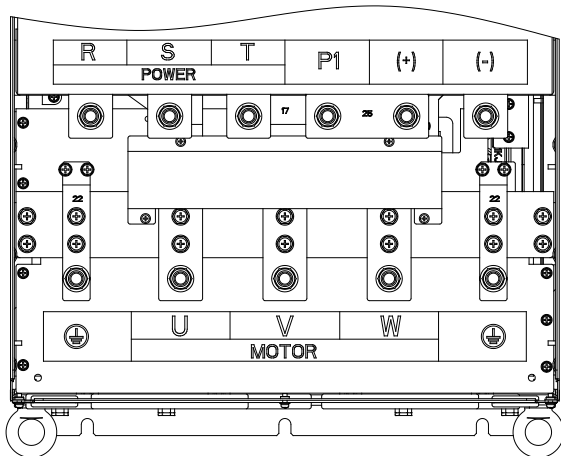

Figure 3-13 Main circuit terminal diagram for 380V 132-200kW VFD models

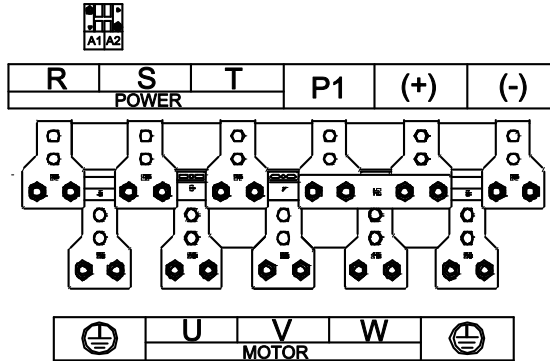

Figure 3-14 Main circuit terminal diagram for 380V 220–350kW VFD models

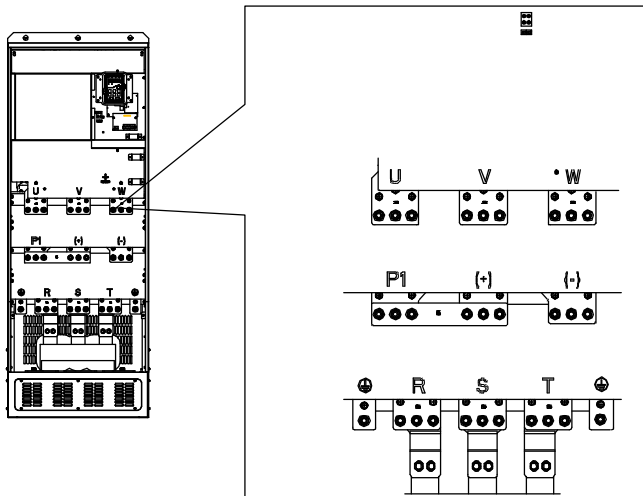



Figure 3-15 Main circuit terminal diagram for 380V 400–500kW VFD models

Table 3-1 Screw specification and torque of main circuit terminals

Power range (kW)	Terminal screw specification	Torque of torque driver (N·m)
7.5–15	M5	2.5
18.5–37	M6	3.5
45–110	M8	10
132–200	M12	35

Power range (kW)	Terminal screw specification	Torque of torque driver (N·m)
220–350	M12	35
400–500	M12	35

Table 3-2 Main circuit terminal description

Terminal sign	Terminal name			Terminal function
	11–15kW	7.5kW and 18.5–110kW	132kW and higher	
R, S, T	Main circuit power input			3PH AC input terminals, connected to the grid
P1	None		DC reactor terminal 1	P1 and (+) connect to DC reactor terminals
(+)	None	Reserved	DC reactor terminal 2	
(-)	None	Reserved	Reserved	
PB	None	Reserved	None	
U, V, W	VFD output			3PH AC output terminals, connected to the motor
	Ground terminal for safety protection			Each machine must be grounded. The grounding is implemented through the two PE terminals on the machine, and the grounding resistance is less than 10Ω.

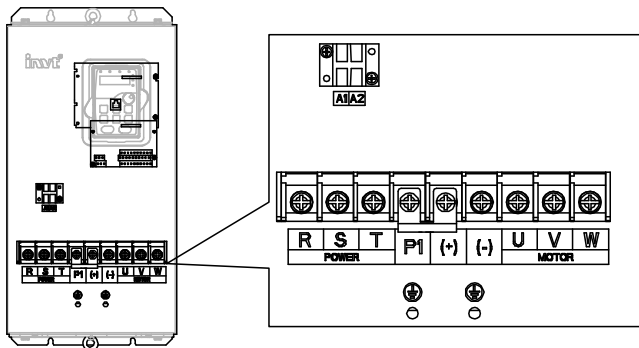

Figure 3-16 Main circuit terminal diagram for 660V 22–45kW VFD models

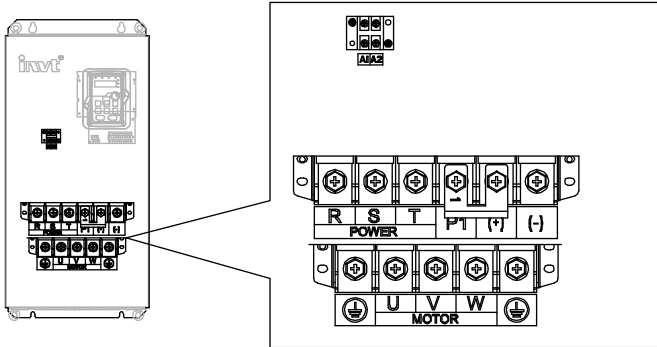

Figure 3-17 Main circuit terminal diagram for 660V 55–132kW VFD models

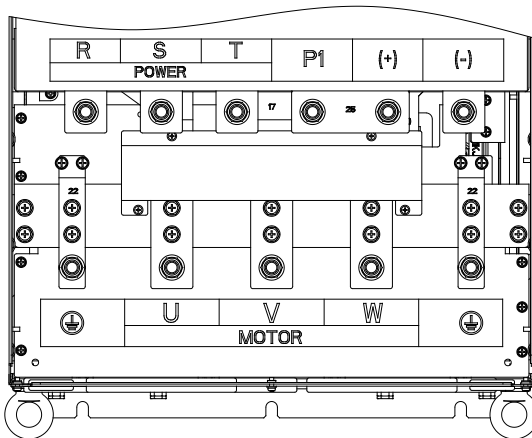

Figure 3-18 Main circuit terminal diagram for 660V 160–220kW VFD models

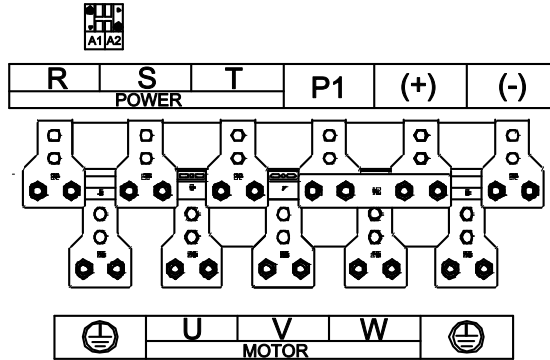

Figure 3-19 Main circuit terminal diagram for 660V 250–350kW VFD models

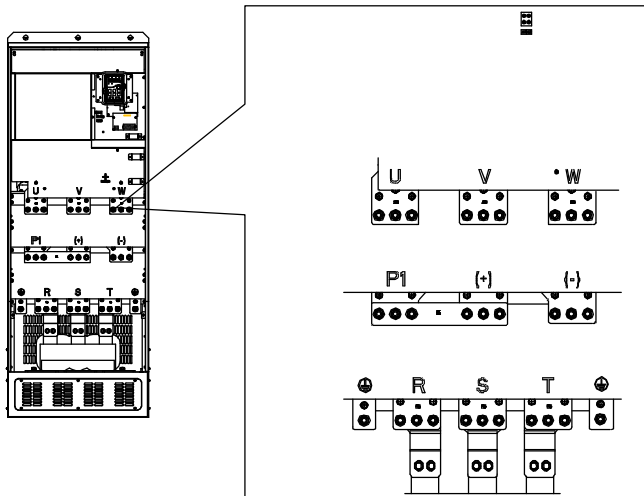



Figure 3-20 Main circuit terminal diagram for 660V 400–630kW VFD models

Table 3-3 Screw specification and torque of main circuit terminals

Power range (kW)	Terminal screw specification	Torque of torque driver (N·m)
22–45	M6	3.5
55–132	M8	10
160–220	M12	35
250–350	M12	35

Power range (kW)	Terminal screw specification	Torque of torque driver (N·m)
400–630	M12	35

Table 3-4 Main circuit terminal description

Terminal sign	Terminal name		Terminal function
	22–132kW	160kW and higher	
R, S, T	Main circuit power input		3PH AC input terminals, connected to the grid
P1	Reserved	DC reactor terminal 1	P1 and (+) connect to DC reactor terminals
(+)	Reserved	DC reactor terminal 2	
(-)	Reserved	Reserved	
PB	None	None	
U, V, W	VFD output		3PH AC output terminals, connected to the motor
	Grounding terminal for safety protection		Each machine must be grounded. The grounding is implemented through the two PE terminals on the machine, and the grounding resistance is less than 10Ω.

3.2 Control circuit wiring and terminal description

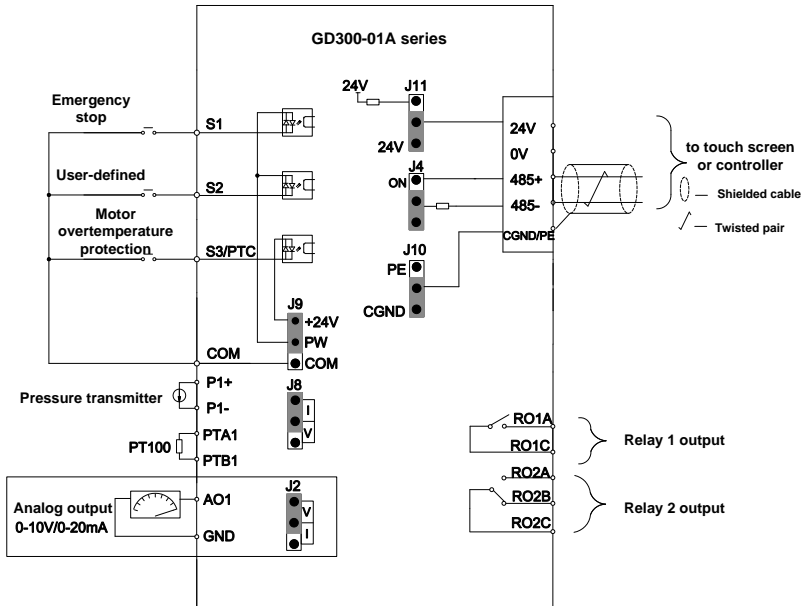

Figure 3-21 Control circuit wiring diagram

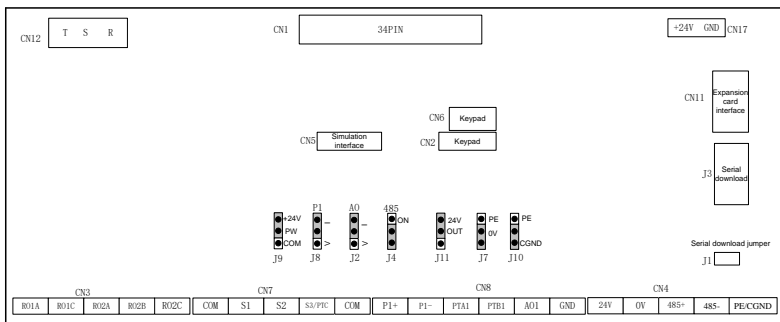

Figure 3-22 Control circuit terminal diagram

Table 3-5 User terminal description of control circuit

Category	Sign	Name	Terminal function
Power supply	24V	24V power supply	Provide 24V*(95%–110%) power to the external, max. output current: 1A. Can be used to power up GPRS and HMI touch

Category	Sign	Name	Terminal function	
			screen. You can select 24V output or 24V and 1.1Ω resistor series connection output through the jumper J11. By default, 24V output is selected in factory.	
	0V	24V reference ground	24V reference ground	
PT100 signal input	PTA1	Analog temperature signal 1	1. Resolution: 1°C 2. Range: -20°C–150°C 3. Detection precision: 3°C	
	PTB1			
Pressure signal input	P1+	Analog pressure signal 1	1. Input range: current/voltage is optional, 4–20mA/2–10V corresponds to 0–1.6MPa; of which P1 is switched via the jumper J8, and the default is input current signal. 2. Input impedance: 30kΩ during voltage input; 500Ω during current input 3. Resolution: 5mV (minimum value) 4. Error: ±1%, 25°C	
	P1-			
Digital input/output	S1	Digital input 1	1. Internal impedance: 3.3kΩ 2. 12–30V voltage input is acceptable 3. Max. input frequency: 1kHz You can select internal power (NPN mode) or external power (PNP mode) through the jumper J9. The default is internal power (NPN mode).	
	S2	Digital input 2		
	S3 / PTC		Digital input 3	1. Internal impedance: 3.3kΩ 2. 12–30V voltage input is acceptable 3. Max. input frequency: 1kHz This channel circuit uses internal power (NPN mode).
			Motor overtemperature protection	External PTC temperature switch signal input, PTC resistance acts at 2.3kΩ.
Analog input	AO1	Analog input	1. Output range: 0–10V voltage or 0–20mA current; voltage or current output is switched via the jumper J2. The default is current type. 2. Error: ±1%, 25°C	
	GND		Analog ground	
Communication	485+	RS485 communication	485 communication terminal, adopting the Modbus protocol	
	485-			

Category	Sign	Name	Terminal function
			You can select the matching terminal resistor through the jumper J4. By default, the matching resistor is not connected.
	PE/CGND	Communication cable shielding layer	You can choose to connect the communication cable shielding layer to PE or CGND through the jumper J10. By default, CGND is connected in factory.
Relay output	RO1A	NO contact of relay 1	1. Contact capacity: 3A/AC250V, 1A/DC30V. 2. Cannot be used as high-frequency switch output.
	RO1C	Common contact of relay 1	
	RO2A	NO contact of relay 2	
	RO2B	NC contact of relay 2	
	RO2C	Common contact of relay 2	
Jumper terminal	J9	Internal/external power selection terminal	You can select internal power (NPN mode) or external power (PNP mode) through J9. The default is internal power (NPN mode).
	J8	P1-Analog signal selection terminal	I corresponds to current signal, V corresponds to voltage signal, and the default is current input signal.
	J2	AO analog output signal selection terminal	I corresponds to current signal, V corresponds to voltage signal, and the default is voltage input signal.
	J11	24V power output terminal	You can select 24V output or 24V and 1.1Ω resistor series connection output through the jumper J11. By default, 24V output is selected in factory.
	J4	Terminal for connecting 485 communication terminal resistors	ON corresponds to the connection of terminal resistors. No terminal resistor is connected by default.
	J7	Terminal for short connecting	By default, no short connection in factory. When interferences occur to the touch screen, you can

Category	Sign	Name	Terminal function
		PE to 0V	short connect the jumper J7 between 0V and PE depending on the situation.
	J10	PE/CGND selection terminal	CGND is short connected by default. When interferences occur to communication, you can short connect the jumper J10 to PE so as to help the communication cable shielding layer connect to PE.

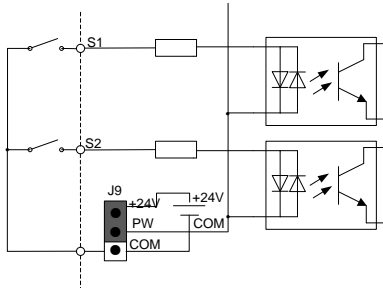

Figure 3-23 Internal power (NPN mode)

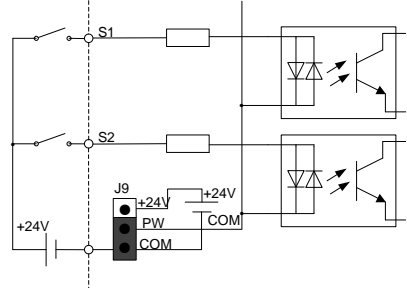

Figure 3-24 External power (PNP mode)

When digital input S1 and S2 use internal +24V, set J9 according to Figure 3-23 and short +24V to PW.

When digital input S1 and S2 use external +24V, set J9 according to Figure 3-24, and short COM to PW.

4 Commissioning instruction

4.1 Commissioning instruction for the dual-VFD air compressor

4.1.1 Wiring diagram of the dual-VFD air compressor system

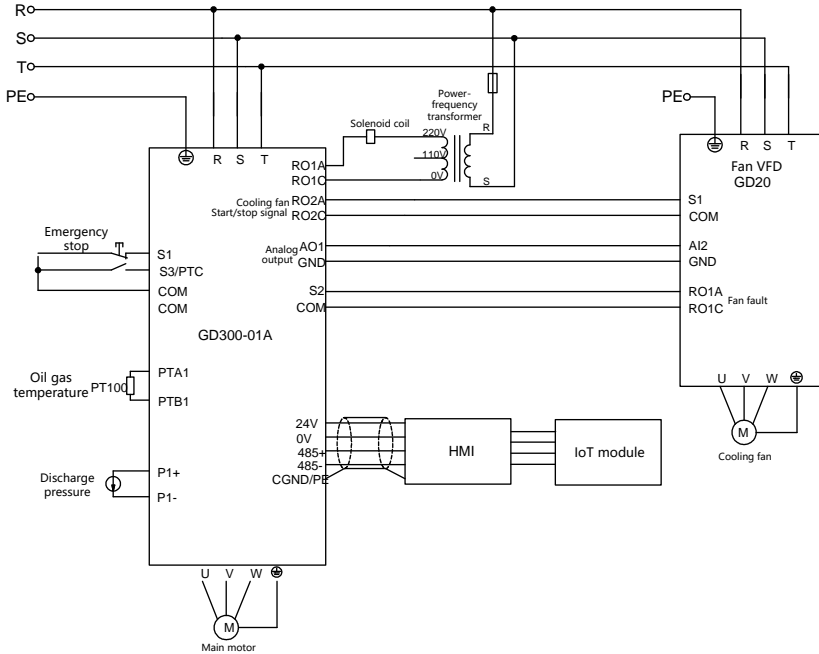

Figure 4-1 Wiring diagram for dual-VFD air compressor system

4.1.2 Commissioning steps for the dual-VFD air compressor

It is recommended to use touch screen special for INVNT air compressor to display and commission.

Note:

- ✧ If you use a controller from another manufacturer, contact INVNT technical support.
- ✧ All the parameters displayed in the interfaces are subject to actual displayed content.

The commissioning steps are as follows:

1. Perform wiring according to Figure 4-1 and ensure that the VFD for air compressor and the housing of the air compressor are grounded properly.
2. After power up, the following interface is displayed.

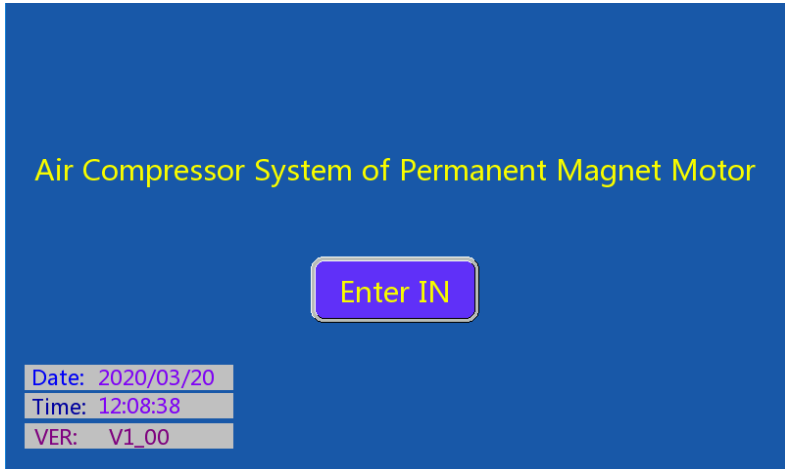

Figure 4-2 Login interface

3. Click **Enter IN** to enter the working environment interface, as shown in Figure 4-3.

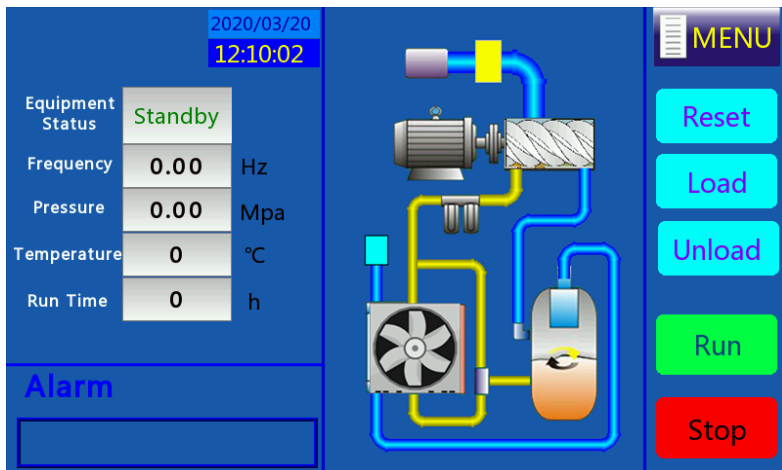

Figure 4-3 Working interface

4. Click **Menu** on the top right corner of the user interface, and the interface is displayed, as shown in Figure 4-4.

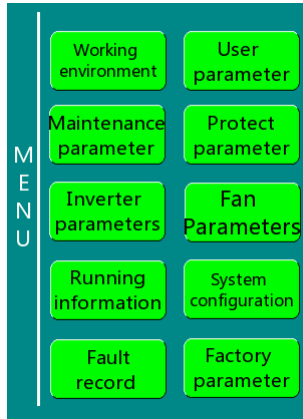

Figure 4-4 Menu interface

5. Click **System config** on the touch screen to enter the system configuration interface, as shown in Figure 4-5.

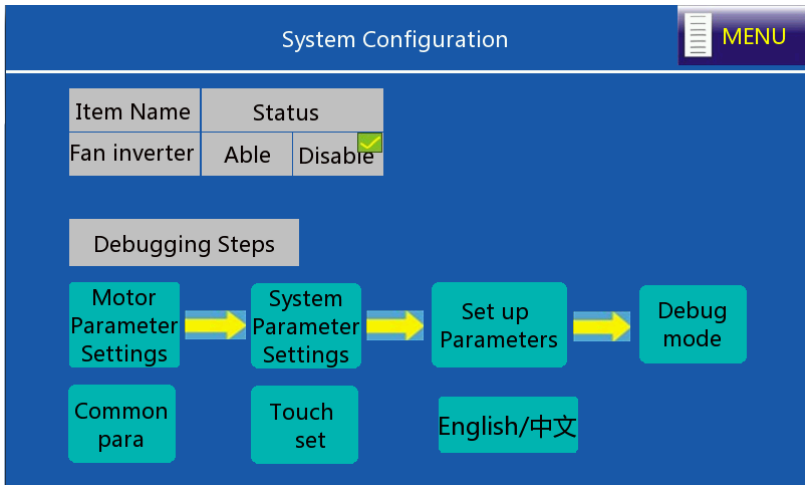

Figure 4-5 System configuration interface

Click **Able** for the fan VFD, and perform commissioning according to the commissioning guide.

Step 1 In the system configuration interface, click **Motor Parameter Settings** to select the motor type.

- ◇ If you select **SM** (synchronous motor), you need to set the max frequency, rated frequency,

rated power, rated voltage, rated current, pole pairs, and carrier frequency.

- ✧ If you select **AM** (asynchronous motor), you need to set the max frequency, rated frequency, rated power, rated voltage, rated current, rated rotational speed, and carrier frequency.



Figure 4-6 Main motor parameter setting interface

Set motor parameters according to the actual motor nameplate parameters, click **Para autotune**, and then click **Next**. On the interface shown in Figure 4-7, set fan motor parameters (including the max frequency, rated frequency, rated power, rated voltage, rated current, and rated rotational speed).

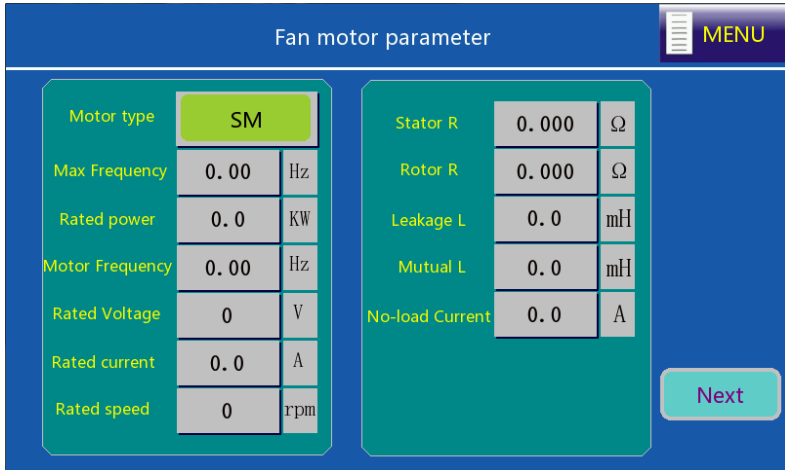

Figure 4-7 Fan motor parameter setting interface

Step 2 On the system configuration interface, click **Set up Parameters**. The system completes the related parameter configuration automatically.

Step 3 Click **Next** to enter **Parameters Configuration** or click **Back** to return to system configuration. On the system configuration interface, click **System Para Config**. S1 functions as emergency-stop switch, select **NO** or **NC** based on the polarity of the emergency-stop switch, as shown in Figure 4-8.

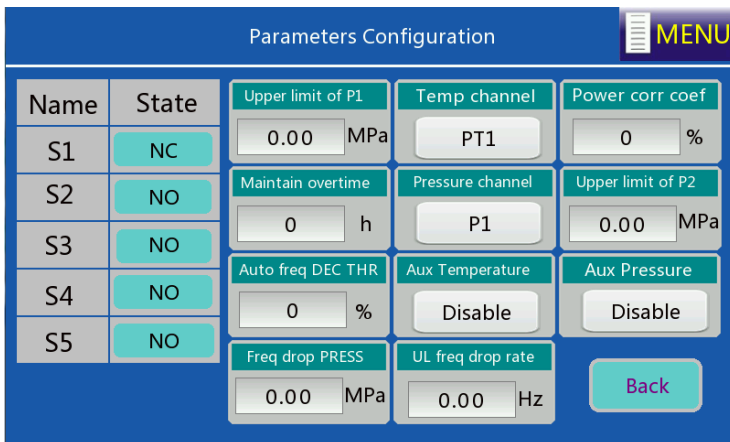

Figure 4-8 System parameter configuration interface

Step 4 On the system configuration interface, click **Debug Mode**, and the interface is displayed, as shown in Figure 4-9.

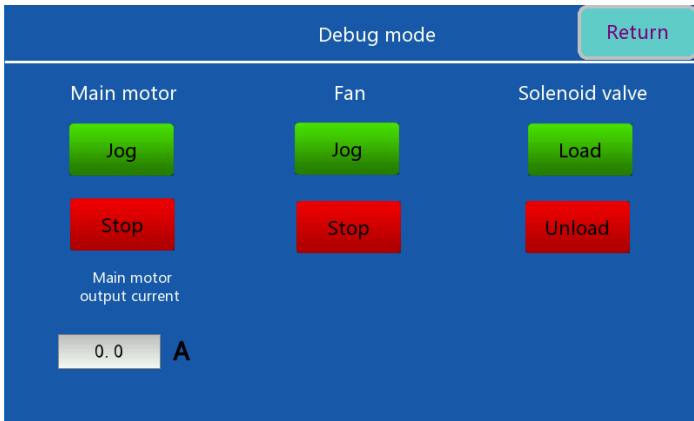

Figure 4-9 Debug mode interface

Click **Jog** for the main motor to determine the motor rotation direction; click **Load** or **Unload** to test the action of solenoid valve. Click **Return** to enter system configuration, then, click **Menu** to return to the menu interface.

Note: If the motor rotates reversely, adjust the wiring sequence of the motor cable.

6. Choose **User parameter** in the menu, and the interface is displayed, as shown in Figure 4-10.

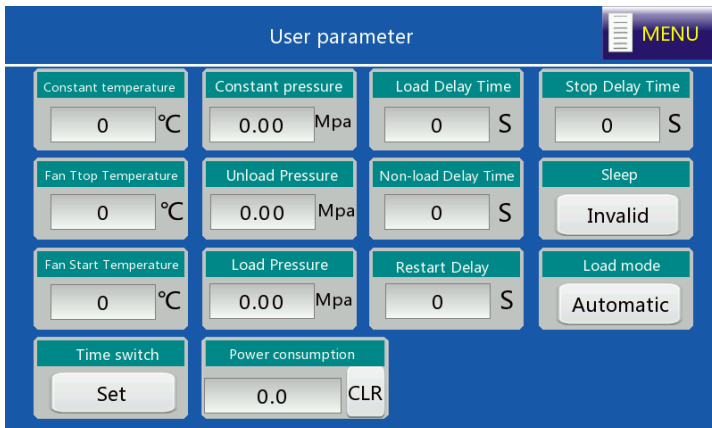

Figure 4-10 User parameter interface

7. Choose **Maintenance parameter** in the menu, and the interface is displayed, as shown in Figure 4-11.

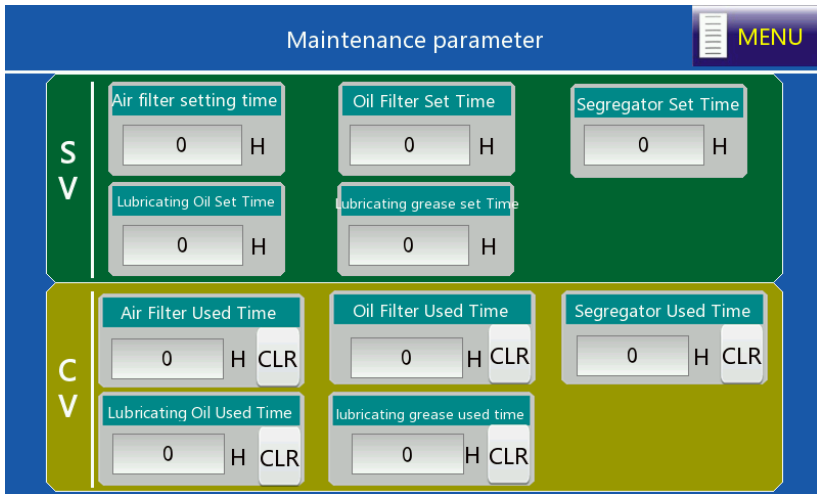

Figure 4-11 Maintenance parameter interface

8. Choose **Protect parameter** in the menu, and the interface is displayed, as shown in Figure 4-12.

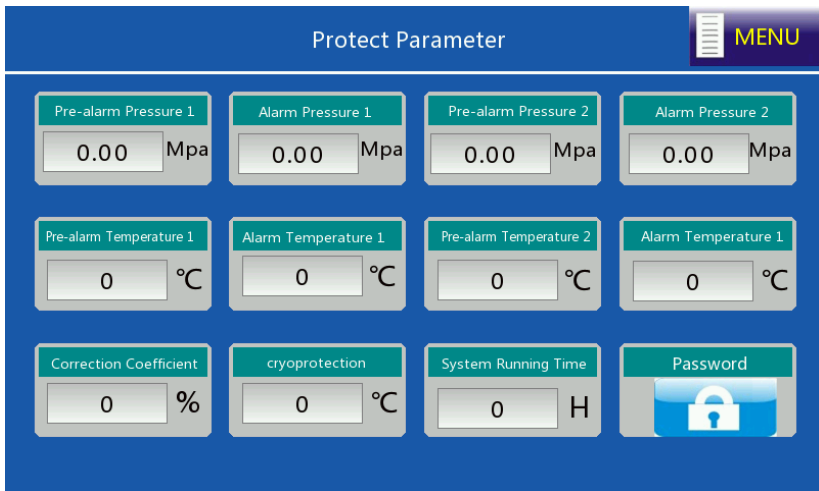

Figure 4-12 Protection parameter interface

9. Choose **Running Info** in the menu, and the interface is displayed, as shown in Figure 4-13.

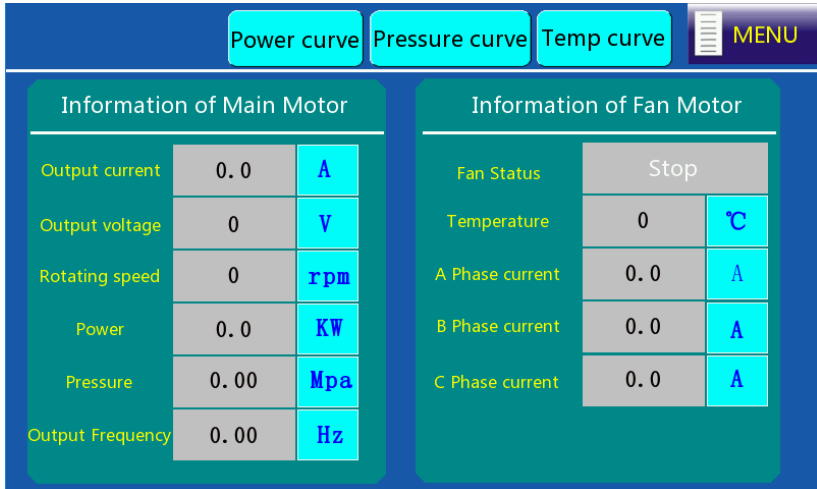

Figure 4-13 Running information interface

- After adjusting user parameters, factory parameters and maintenance parameters according to the manual, return to **Workspace** interface and click **Start** to run.

4.2 Commissioning guidance for single-VFD air compressor

4.2.1 Wiring diagram for single-VFD air compressor system

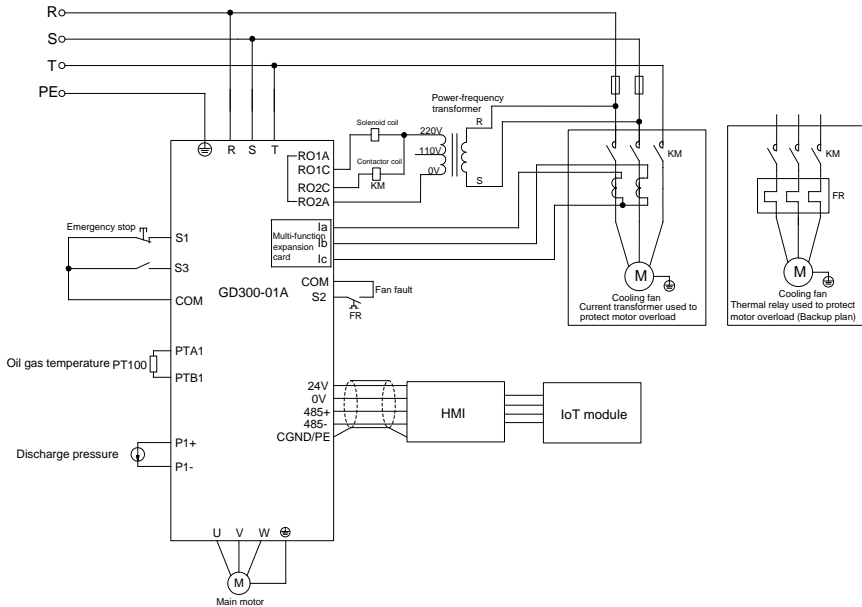

Figure 4-14 Wiring diagram for single-VFD air compressor system

4.2.2 Commissioning steps for single-VFD air compressor

1. Perform similar operations described in section 4.1.2 "Commissioning steps for the dual-VFD air compressor", but you need to turn off the variable-frequency fan on the **System Configuration** interface.

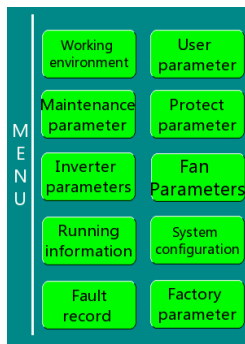

Figure 4-15 Menu interface

2. Choose **Fan Parameters**. Set the fan rated current according to the fan nameplate.

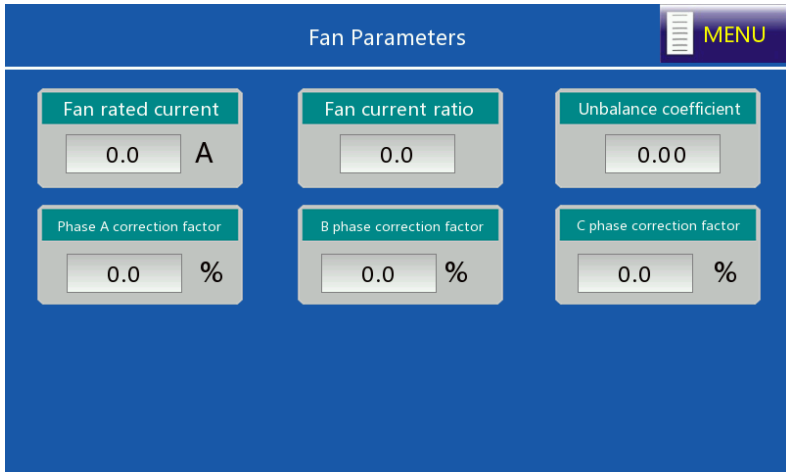

Figure 4-16 Fan parameter interface

3. After adjusting user parameters, factory parameters and maintenance parameters according to the touch screen manual, return to the Working environment interface, and click **Start** to run.

5 Function description

5.1 Function parameter list

"○" indicates that the value of the parameter can be modified when the VFD is in stopped or running state.

"◎" indicates that the value of the parameter cannot be modified when the VFD is in running state.

"●" indicates that the value of the parameter is the actually detected value which cannot be modified.

(The VFD automatically checks and constrains the modification of parameters, which helps prevent incorrect modifications.)

P00 group Basic functions

Function code	Name	Description	Default	Modify
P00.00	Speed control mode	0: SVC mode 0 (applicable to AM, SM) 1: SVC mode 1 (applicable to AM) 2: V/F control Note: AM: Asynchronous Motor; SM: Synchronous Motor; If vector mode is adopted, it is a must to carry out motor parameter autotuning on the VFD first.	0	◎
P00.01	Channel of running commands	0: Keypad (LED off) 1: Terminal (LED blinks) 2: Communication (LED on)	0	○
P00.02	Communication mode of running commands	0: Modbus communication 1-3: Reserved	0	○
P00.03	Max. output frequency	P00.04 –400.00Hz	50.00Hz	◎
P00.04	Upper limit of running frequency	P00.05 – P00.03 (max. output frequency)	50.00Hz	○
P00.05	Lower limit of running frequency	0.00Hz– P00.04 (upper limit of running frequency)	0.00Hz	○

Function code	Name	Description	Default	Modify
P00.06	Setting channel of A frequency command	0: Keypad 1: Analog P1- 2: Reserved 3: Analog P2- 4: Reserved 5: Reserved	0	<input type="radio"/>
P00.07	Setting channel of B frequency command	6: Multi-step speed running 7: PID control 8: Modbus communication 9-11: Reserved Note: A frequency and B frequency cannot use the same frequency reference mode. You can set the frequency source through P00.09 .	2	<input type="radio"/>
P00.08	Reference object of B frequency command	0: Max. output frequency 1: A frequency command	0	<input type="radio"/>
P00.09	Combination mode of setting source	0: A 1: B 2: (A+B) 3: (A- B) 4: Max(A, B) 5: Min. (A, B)	0	<input type="radio"/>
P00.10	Frequency set through keypad	0.00 Hz- P00.03 (max. output frequency)	50.00Hz	<input type="radio"/>
P00.11	ACC time 1	0.0-3600.0s	Model depended	<input type="radio"/>
P00.12	DEC time 1	0.0-3600.0s	Model depended	<input type="radio"/>
P00.13	Running direction	0: Run at the default direction. 1: Run at the opposite direction. 2: Disable reverse running	2	<input type="radio"/>
P00.14	Carrier frequency setting	1.0-8.0kHz	Model depended	<input type="radio"/>

Function code	Name	Description	Default	Modify
P00.15	Motor parameter autotuning	0: No operation 1: Rotary autotuning 2: Static autotuning 1 (comprehensive autotuning) 3: Static autotuning 2 (partial autotuning, only support asynchronous motor)	0	☉
P00.16	AVR function selection	0: Disable 1: Valid during the whole procedure	1	○
P00.18	Function parameter restore	0: No operation 1: Restore to default value 2: Clear fault history 3: Start/stop the VFD with one click in communication mode 4: Start/stop the VFD with one click in terminal mode Note: Though restoring to default values is enabled, the motor parameters in P02 group remain unchanged; P18.04 , P18.28 , P18.29 , P18.32 , P18.33 , P18.38 , P21.04 , P21.05 , and P21.06 also remain unchanged.	0	☉

P01 group Start and stop control

Function code	Name	Description	Default	Modify
P01.00	Start mode	0: Direct start 1: Start after DC braking	0	☉
P01.01	Starting frequency of direct start	0.00–50.00Hz	0.50Hz	☉
P01.02	Starting frequency hold time	0.00–50.00s	0.00s	☉
P01.03	Braking current before start	0.0–150.0%	0.0%	☉
P01.04	Braking time before start	0.00–50.00s	0.00s	☉
P01.05	ACC and DEC mode	0: Linear	0	○
P01.08	Stop mode	0: Decelerate to stop 1: Coast to stop	0	○

Function code	Name	Description	Default	Modify
P01.09	Starting frequency of DC braking for stop	0.00–P00.03 (max. output frequency)	0.00Hz	<input type="radio"/>
P01.10	Wait time before DC braking for stop	0.00–50.00s	0.00s	<input type="radio"/>
P01.11	DC braking current for stop	0.0–150.0%	0.0%	<input type="radio"/>
P01.12	DC braking time for stop	0.00–50.00s	0.00s	<input type="radio"/>
P01.13	FWD/REV running deadzone time	0.0–3600.0s	0.0s	<input type="radio"/>
P01.14	FWD/REV running switching mode	0: Switch at zero frequency 1: Switch at the starting frequency 2: Switch after the speed reaches the stop speed with a delay	0	<input checked="" type="radio"/>
P01.15	Stop speed	0.00–100.00Hz	5.00Hz	<input checked="" type="radio"/>
P01.16	Stop speed detection mode	0: Detect as per the set speed value (judge the ramps frequency) 1: Detect as per the speed feedback value (valid for vector control only)	1	<input checked="" type="radio"/>
P01.17	Feedback speed detection time	0.00–100.00s (valid only when P01.16=1)	0.50s	<input checked="" type="radio"/>
P01.18	Terminal-based running command protection at power-on	0: The terminal running command is invalid at power-on 1: The terminal running command is valid at power-on	0	<input type="radio"/>
P01.19	Action selected when running frequency less than frequency lower limit (valid when frequency lower limit greater than 0)	0: Run at the frequency lower limit 1: Stop 2: Sleep	0	<input checked="" type="radio"/>
P01.20	Wake-up-from-sleep delay	0.0–3600.0s (valid when P01.14=2)	0.0s	<input type="radio"/>
P01.21	Power-off restart selection	0: Disable 1: Enable	0	<input type="radio"/>

Function code	Name	Description	Default	Modify
P01.22	Wait time for restart after power-off	0.0–3600.0s (valid when P01.21=1)	1.0s	<input type="radio"/>
P01.23	Start delay	0.0–60.0s	0.0s	<input type="radio"/>
P01.24	Stop speed delay	0.0–100.0 s	0.0s	<input type="radio"/>
P01.25	0Hz output	0: Output without voltage 1: Output with voltage 2: Output with the DC braking current for stop	0	<input type="radio"/>

P02 group Motor 1 parameters

Function code	Name	Description	Default	Modify
P02.00	Type of motor 1	0: Asynchronous motor (AM) 1: Synchronous motor (SM)	0	<input checked="" type="radio"/>
P02.01	Rated power of AM 1	0.1–3000.0kW	Model depended	<input checked="" type="radio"/>
P02.02	Rated frequency of AM 1	0.01Hz– P00.03 (max. output frequency)	50.00Hz	<input checked="" type="radio"/>
P02.03	Rated speed of AM 1	1–36000rpm	Model depended	<input checked="" type="radio"/>
P02.04	Rated voltage of AM 1	0–1200V	Model depended	<input checked="" type="radio"/>
P02.05	Rated current of AM 1	0.8–6000.0A	Model depended	<input checked="" type="radio"/>
P02.06	Stator resistance of AM 1	0.001–65.535Ω	Model depended	<input type="radio"/>
P02.07	Rotor resistance of AM 1	0.001–65.535Ω	Model depended	<input type="radio"/>
P02.08	Leakage inductance of AM 1	0.1–6553.5mH	Model depended	<input type="radio"/>
P02.09	Mutual inductance of AM 1	0.1–6553.5mH	Model depended	<input type="radio"/>

Function code	Name	Description	Default	Modify
P02.10	No-load current of AM 1	0.1–6553.5A	Model depended	○
P02.11	Magnetic saturation coefficient 1 of iron core of AM 1	0.0–100.0%	80.0%	◎
P02.12	Magnetic saturation coefficient 2 of iron core of AM 1	0.0–100.0%	68.0%	◎
P02.13	Magnetic saturation coefficient 3 of iron core of AM 1	0.0–100.0%	57.0%	◎
P02.14	Magnetic saturation coefficient 4 of iron core of AM 1	0.0–100.0%	40.0%	◎
P02.15	Rated power of SM 1	0.1–3000.0kW	Model depended	◎
P02.16	Rated frequency of SM 1	0.01Hz– P00.03 (max. output frequency)	50.00Hz	◎
P02.17	Number of pole pairs of SM 1	1–50	2	◎
P02.18	Rated voltage of SM 1	0–1200V	Model depended	◎
P02.19	Rated current of SM 1	0.8–6000.0A	Model depended	◎
P02.20	Stator resistance of SM 1	0.001–65.535Ω	Model depended	○

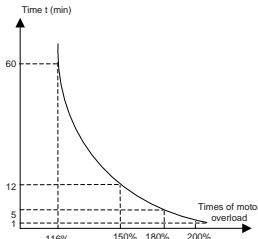
Function code	Name	Description	Default	Modify
P02.21	Direct-axis inductance of SM 1	0.01–655.35mH	Model depended	<input type="radio"/>
P02.22	Quadrature-axis inductance of SM 1	0.01–655.35mH	Model depended	<input type="radio"/>
P02.23	Counter-emf constant of SM 1	0–10000	350	<input type="radio"/>
P02.26	Overload protection selection of motor 1	0: No protection 1: Normal motor (with low speed compensation) 2: Variable-frequency motor (without low speed compensation)	2	<input checked="" type="radio"/>
P02.27	Overload protection coefficient of motor 1	<p>Motor overload multiple $M = I_{out}/(I_n \cdot K)$ I_n is rated motor current, I_{out} is VFD output current, K is motor overload protection coefficient. A smaller value of K indicates a bigger value of M. When $M=116\%$, protection is performed after motor overload lasts for 1 hour; when $M=150\%$, protection is performed after motor overload lasts for 12 minutes; when $M=180\%$, protection is performed after motor overload lasts for 5 minutes; when $M=200\%$, protection is performed after motor overload lasts for 60 seconds; and when $M \geq 400\%$, protection is performed immediately.</p>  <p>Setting range: 20.0%–120.0%</p>	100.0%	<input type="radio"/>

Function code	Name	Description	Default	Modify
P02.28	Power calibration coefficient of motor 1	0.00–3.00	1.00	<input type="radio"/>
P02.29	Parameter display selection of motor 1	0: Displayed according to the motor type 1: All displayed	0	<input type="radio"/>

P03 group Vector control

Function code	Name	Description	Default	Modify
P03.00	Speed-loop proportional gain 1	0–200.0	20.0	<input type="radio"/>
P03.01	Speed-loop integral time 1	0.000–10.000s	0.200s	<input type="radio"/>
P03.02	Low-point frequency for switching	0.00Hz– P03.05	5.00Hz	<input type="radio"/>
P03.03	Speed-loop proportional gain 2	0–200.0	20.0	<input type="radio"/>
P03.04	Speed-loop integral time 2	0.000–10.000s	0.200s	<input type="radio"/>
P03.05	High-point frequency for switching	P03.02 – P00.03 (max. output frequency)	10.00Hz	<input type="radio"/>
P03.06	Speed-loop output filter	0–8 (corresponding to $0-2^8/10$ ms)	0	<input type="radio"/>
P03.07	Electromotive slip compensation coefficient of vector control	50%–200.0%	100%	<input type="radio"/>

Function code	Name	Description	Default	Modify																		
P03.08	Power generation slip compensation coefficient of vector control	50%–200.0%	100%	<input type="radio"/>																		
P03.09	ACR proportional coefficient P	0–65535 The default value of P03.09 and P03.10 is different within differing power ranges, and the default value will be configured as below after autotuning and setting power range via the touch screen.	Model depended	<input type="radio"/>																		
P03.10	ACR integral coefficient I	<table border="1"> <thead> <tr> <th>P03.09 value (reference)</th> <th>P03.10 value (reference)</th> <th>Motor power</th> </tr> </thead> <tbody> <tr> <td>2000</td> <td>1000</td> <td>7.5–22kW</td> </tr> <tr> <td>2500</td> <td>1500</td> <td>30–37kW</td> </tr> <tr> <td>3000</td> <td>1500</td> <td>45–90kW</td> </tr> <tr> <td>3500</td> <td>2000</td> <td>110–132kW</td> </tr> <tr> <td>4000</td> <td>2000</td> <td>160–315 kW</td> </tr> </tbody> </table>	P03.09 value (reference)	P03.10 value (reference)	Motor power	2000	1000	7.5–22kW	2500	1500	30–37kW	3000	1500	45–90kW	3500	2000	110–132kW	4000	2000	160–315 kW	Model depended	<input type="radio"/>
P03.09 value (reference)	P03.10 value (reference)	Motor power																				
2000	1000	7.5–22kW																				
2500	1500	30–37kW																				
3000	1500	45–90kW																				
3500	2000	110–132kW																				
4000	2000	160–315 kW																				
P03.11	Torque setting method	0: Torque control is invalid 1: Keypad (P03.12) 2: P1- (100% corresponding to three times the motor rated current) 3: Reserved 4: P2- (100% corresponding to three times the motor rated current) 5–6: Reserved 7: Modbus communication (same as the above) 8–10: Reserved	0	<input type="radio"/>																		
P03.12	Torque set through keypad	-300.0%–300.0% (of the motor rated current)	50.0%	<input type="radio"/>																		
P03.13	Torque reference filter time	0.000–10.000s	0.010s	<input type="radio"/>																		
P03.14	Setting source of forward	0: Keypad (P03.16) 1: P1- (100% corresponding to the max.	0	<input type="radio"/>																		

Function code	Name	Description	Default	Modify
	rotation upper-limit frequency in torque control	frequency) 2: Reserved 3: P2- (100% corresponding to the max. frequency) 4-5: Reserved 6: Modbus communication (same as the above) 7-9: Reserved		
P03.15	Setting source of reverse rotation upper-limit frequency in torque control	0: Keypad (P03.17) 1: P1- (100% corresponding to the max. frequency) 2: Reserved 3: P2- (100% corresponding to the max. frequency) 4-5: Reserved 6: Modbus communication (same as the above) 7-9: Reserved	0	○
P03.16	Forward rotation upper-limit frequency set through keypad in torque control	0.00Hz-P00.03	50.00Hz	○
P03.17	Reverse rotation upper-limit frequency set through keypad in torque control	0.00 Hz-P00.03	50.00Hz	○
P03.18	Setting source of electromotive torque upper limit	0: Keypad (P03.20) 1: P1- (100% corresponding to three times the motor rated current) 2: Reserved 3: P2- (100% corresponding to three times the motor rated current)	0	○

Function code	Name	Description	Default	Modify
		4: Reserved 5: Modbus communication (same as the above) 6–8: Reserved		
P03.19	Setting source of braking torque upper limit	0: Keypad (P03.21) 1: P1- (100% corresponding to three times the motor rated current) 2: Reserved 3: P2- (100% corresponding to three times the motor rated current) 4: Reserved 5: Modbus communication (same as the above) 6–8: Reserved	0	<input type="radio"/>
P03.20	Electromotive torque upper limit set through keypad	0.0–300.0% (of the motor rated current)	180.0%	<input type="radio"/>
P03.21	Braking torque upper limit set through keypad	0.0–300.0% (of the motor rated current)	180.0%	<input type="radio"/>
P03.22	Weakening coefficient in constant power zone	0.1–2.0	0.3	<input type="radio"/>
P03.23	Lowest weakening point in constant power zone	10%–100.0%	20%	<input type="radio"/>
P03.24	Max. voltage limit	0.0–120.0%	100.0%	<input type="radio"/>
P03.25	Pre-exciting time	0.000–10.000s	0.300s	<input type="radio"/>
P03.26	Flux-weakening proportional gain	0–8000	300	<input type="radio"/>

Function code	Name	Description	Default	Modify
P03.27	Speed display selection in vector control	0: Display the actual value 1: Display the set value	0	<input type="radio"/>
P03.28	IF starting current	0–100.0% (of the motor rated current)	60.0%	<input type="radio"/>
P03.29	Inductance coefficient	0.2–40.0	1.0	<input type="radio"/>

P04 group SVPWM control

Function code	Name	Description	Default	Modify
P04.00	V/F curve setting of motor 1	0: Straight-line V/F curve 1: Multi-point V/F curve 2–5: Reserved	0	<input checked="" type="radio"/>
P04.01	Torque boost of motor 1	0.0%: (automatic); 0.1%–10.0%	0.0%	<input type="radio"/>
P04.02	Torque boost cut-off of motor 1	0.0%–50.0% (relative to rated frequency of motor 1)	20.0%	<input type="radio"/>
P04.03	V/F frequency point 1 of motor 1	0.00Hz– P04.05	0.00Hz	<input type="radio"/>
P04.04	V/F voltage point 1 of motor 1	0.0%–110.0% (of the rated voltage of motor 1)	00.0%	<input type="radio"/>
P04.05	V/F frequency point 2 of motor 1	P04.03 – P04.07	00.00Hz	<input type="radio"/>
P04.06	V/F voltage point 2 of motor 1	0.0%–110.0% (of the rated voltage of motor 1)	00.0%	<input type="radio"/>
P04.07	V/F frequency point 3 of motor 1	P04.05 – P02.02 (rated frequency of AM 1) P04.05 – P02.16 (rated frequency of SM 1)	00.00Hz	<input type="radio"/>
P04.08	V/F voltage point 3 of motor 1	0.0%–110.0% (of the rated voltage of motor 1)	00.0%	<input type="radio"/>

Function code	Name	Description	Default	Modify
P04.09	V/F slip compensation gain of motor 1	0.0–200.0%	100.0%	○
P04.10	Low-frequency oscillation control factor of motor 1	0–100	10	○
P04.11	High-frequency oscillation control factor of motor 1	0–100	10	○
P04.12	Oscillation control threshold of motor 1	0.00Hz– P00.03 (max. output frequency)	30.00Hz	○
P04.26	Energy-saving run	0: Disable 1: Automatic energy-saving run	0	◎
P04.33	Weakening coefficient in constant power zone	1.00–1.30	1.00	○
P04.34	Reactive closed-loop proportional coefficient	0–3000	100	○
P04.35	Reactive closed-loop integral coefficient	0–3000	30	○

P05 group Input terminals

Function code	Name	Description	Default	Modify
P05.00	Reserved	Reserved	0	◎
P05.01	Function of S1	0: No function	0	◎
P05.02	Function of S2	1: Run forward	0	◎
P05.03	S3/PTC terminal	2: Run reversely 3: Three-wire running control	0	◎

Function code	Name	Description	Default	Modify																				
	function selection	4: Jog forward 5: Jog reversely																						
P05.04	Function of S4	6: Coast to stop	0	⊙																				
P05.05	Function of S5	7: Reset faults	0	⊙																				
P05.06	Function of S6	8: Pause running	0	⊙																				
P05.07	Function of S7	9: External fault input	0	⊙																				
P05.08	Function of S8	10–24: Reserved 25: Pause PID control 26–39: Reserved 40: Clear electricity consumption 41: Keep electricity consumption 42: Air filter blockage signal 43: Oil filter blockage signal 44: Separator blockage signal 45: Precision splitter blockage signal 46: External fault 1 (motor overtemperature) 47: External fault 2 48: Fan running control signal 49: Solenoid valve control signal 50: Cooling fan control signal of main motor 51: PTC signal 52: Low water level detection (only for water lubrication) 53: Medium water level detection (only for water lubrication) 54: High water level detection (only for water lubrication) 55: Extra water level detection (only for water lubrication) 51–63: Reserved	0	⊙																				
P05.10	Input terminal polarity	<p>The function code is used to set the polarity of input terminals. When a bit is 0, the input terminal is positive; when a bit is 1, the input terminal is negative.</p> <table border="1" style="margin-left: auto; margin-right: auto;"> <tr> <td></td> <td></td> <td>BIT7</td> <td>BIT6</td> <td>BIT5</td> </tr> <tr> <td></td> <td></td> <td>S8</td> <td>S7</td> <td>S6</td> </tr> <tr> <td>BIT4</td> <td>BIT3</td> <td>BIT2</td> <td>BIT1</td> <td>BIT0</td> </tr> <tr> <td>S5</td> <td>S4</td> <td>S3</td> <td>S2</td> <td>S1</td> </tr> </table>			BIT7	BIT6	BIT5			S8	S7	S6	BIT4	BIT3	BIT2	BIT1	BIT0	S5	S4	S3	S2	S1	0x00	○
		BIT7	BIT6	BIT5																				
		S8	S7	S6																				
BIT4	BIT3	BIT2	BIT1	BIT0																				
S5	S4	S3	S2	S1																				

Function code	Name	Description	Default	Modify
		Setting range: 0x00 –0xFF		
P05.11	Digital input filter time	0.000–1.000s	0.100s	<input type="radio"/>
P05.12	Virtual terminal setting	0: Virtual terminals are invalid 1: Modbus communication virtual terminals are valid 2–4: Reserved	0	<input checked="" type="radio"/>
P05.13	Terminal control mode	0: 2-wire control 1 1: 2-wire control 2 2: 3-wire control 1 3: 3-wire control 2	0	<input checked="" type="radio"/>
P05.14	S1 switch-on delay	0.000–50.000s	0.000s	<input type="radio"/>
P05.15	S1 switch-off delay	0.000–50.000s	0.000s	<input type="radio"/>
P05.16	S2 switch-on delay	0.000–50.000s	0.000s	<input type="radio"/>
P05.17	S2 switch-off delay	0.000–50.000s	0.000s	<input type="radio"/>
P05.18	S3/PTC terminal switch-on delay	0.000–50.000s	0.000s	<input type="radio"/>
P05.19	S3/PTC terminal switch-off delay	0.000–50.000s	0.000s	<input type="radio"/>
P05.20	S4 switch-on delay	0.000–50.000s	0.000s	<input type="radio"/>
P05.21	S4 switch-off delay	0.000–50.000s	0.000s	<input type="radio"/>
P05.22	S5 switch-on delay	0.000–50.000s	0.000s	<input type="radio"/>
P05.23	S5 switch-off delay	0.000–50.000s	0.000s	<input type="radio"/>
P05.24	S6 switch-on delay	0.000–50.000s	0.000s	<input type="radio"/>
P05.25	S6 switch-off delay	0.000–50.000s	0.000s	<input type="radio"/>

Function code	Name	Description	Default	Modify
P05.26	S7 switch-on delay	0.000–50.000s	0.000s	<input type="radio"/>
P05.27	S7 switch-off delay	0.000–50.000s	0.000s	<input type="radio"/>
P05.28	S8 switch-on delay	0.000–50.000s	0.000s	<input type="radio"/>
P05.29	S8 switch-off delay	0.000–50.000s	0.000s	<input type="radio"/>
P05.32	P1 lower limit	0.00V– P05.34	2.00V	<input type="radio"/>
P05.33	Corresponding setting of P1 lower limit	-100.0%–100.0%	0.0%	<input type="radio"/>
P05.34	P1 upper limit	P05.32 –10.00V	10.00V	<input type="radio"/>
P05.35	Corresponding setting of P1 upper limit	-100.0%–100.0%	100.0%	<input type="radio"/>
P05.36	P1 input filter time	0.000s–10.000s	0.200s	<input type="radio"/>
P05.37	PT1 lower limit	0.00V– P05.39	0.00V	<input type="radio"/>
P05.38	Corresponding setting of PT1 lower limit	-100.0%–100.0%	6.3%	<input type="radio"/>
P05.39	PT1 upper limit	P05.37 –10.00V	10.00V	<input type="radio"/>
P05.40	Corresponding setting of PT1 upper limit	-100.0%–100.0%	75.0%	<input type="radio"/>
P05.41	PT1 input filter time	0.000s–10.000s	0.300s	<input type="radio"/>
P05.42	P2 lower limit	0.00V– P05.44	2.00V	<input type="radio"/>
P05.43	Corresponding setting of P2 lower limit	-100.0%–100.0%	0.0%	<input type="radio"/>
P05.44	P2 upper limit	P05.42 –10.00V	10.00V	<input type="radio"/>
P05.45	Corresponding setting of P2 upper limit	-100.0%–100.0%	100.0%	<input type="radio"/>

Function code	Name	Description	Default	Modify
P05.46	P2 input filter time	0.000s–10.000s	0.200s	<input type="radio"/>
P05.47	PT2 lower limit	0.00V– P05.49	0.00V	<input type="radio"/>
P05.48	Corresponding setting of PT2 lower limit	-100.0%–100.0%	6.3%	<input type="radio"/>
P05.49	PT2 upper limit	P05.47 –10.00V	10.00V	<input type="radio"/>
P05.50	Corresponding setting of PT2 upper limit	-100.0%–100.0%	75.0%	<input type="radio"/>
P05.51	PT2 input filter time	0.000s–10.000s	0.300s	<input type="radio"/>
P05.52	P1 analog input type selection	0: Voltage 1: Current Note: When switching the P1 analog input type, it is necessary to ensure that the position of P1 jumper cap on the main control board is correct. In addition, you need to modify P05.52, otherwise deviation may occur in the accuracy of the P1 analog input.	1	<input type="radio"/>
P05.53	P2 analog input type selection	0: Voltage 1: Current Note: When switching the P2 analog input type, it is necessary to ensure that the position of P2 jumper cap on the expansion board is correct. In addition, you need to modify P05.53, otherwise deviation may occur in the accuracy of the P2 analog input.	1	<input type="radio"/>

P06 group Output terminals

Function code	Name	Description	Default	Modify
P06.00	RO4 output	0: Disable 1: Running 2: Running forward	0	<input type="radio"/>

Function code	Name	Description	Default	Modify
P06.01	RO5 output	3: Running reversely 4: Jogging 5: VFD in fault	0	<input type="radio"/>
P06.02	RO3 output	6: FDT1 7: Reserved 8: Frequency reached 9: Running in zero speed	0	<input type="radio"/>
P06.03	RO1 output	10: Upper limit frequency reached 11: Lower limit frequency reached 12: Ready for running 13: Pre-exciting	0	<input type="radio"/>
P06.04	RO2 output	14: Overload pre-alarm 15: Underload pre-alarm 16–19: Reserved 20: External fault is valid 21–22: Reserved 23: Modbus communication virtual terminal output 24–26: Reserved 27: Fan running control (only for air compressors) 28: Loading valve control output (only for air compressors) 29: Master cooling fan control 30: System fault (only for air compressors) 31: Water shut-off valve control (only for water lubrication) 32: Water replenishing valve control (only for water lubrication) 33: Water discharging valve control (only for water lubrication) 34: Water heater valve control (only for water lubrication) 35: Emptying valve control (water lubrication/ acetylene)	0	<input type="radio"/>
P06.05	Output terminal polarity selection	The function code is used to set the polarity of output terminals. When a bit is 0, the input terminal is positive; when a bit is 1, the input terminal is negative.	0	<input type="radio"/>

Function code	Name	Description					Default	Modify
				BIT7	BIT6	BIT5		
				/	/	RO6		
		BIT4	BIT3	BIT2	BIT1	BIT0		
		RO2	RO1	RO3	RO5	RO4		
Setting range: 0–0x3F								
P06.06	RO5 switch-on delay	0.000–50.000s					0.000s	○
P06.07	RO5 switch-off delay	0.000–50.000s					0.000s	○
P06.08	RO3 switch-on delay	0.000–50.000s					0.000s	○
P06.09	RO3 switch-off delay	0.000–50.000s					0.000s	○
P06.10	RO1 switch-on delay	0.000–50.000s					0.000s	○
P06.11	RO1 switch-off delay	0.000–50.000s					0.000s	○
P06.12	RO2 switch-on delay	0.000–50.000s					0.000s	○
P06.13	RO2 switch-off delay	0.000–50.000s					0.000s	○
P06.14	AO1 output selection	0: Running frequency 1: Set frequency 2: Ramp reference frequency 3: Running speed (relative to two times the synchronous rotation speed of the motor) 4: Output current (relative to two times the rated current of the VFD) 5: Output current (relative to two times the					24	○

Function code	Name	Description	Default	Modify
		rated current of the motor) 6: Output voltage (relative to 1.5 times the rated voltage of the VFD) 7: Output power (relative to two times the rated power of the motor) 8: Reserved 9: Output torque (relative to two times the rated torque of the motor) 10–13: Reserved 14: Value 1 set through Modbus communication 15: Value 2 set through Modbus communication 16–21: Reserved 22: Torque current (relative to three times the rated current of the motor) 23: Ramp reference frequency (with sign) 24: Temperature PID output 25–30: Reserved		
P06.15	RO6 output selection	Same as P06.00–P06.04	0	○
P06.17	AO1 output lower limit	-100.0%– P06.19	0.0%	○
P06.18	AO1 output corresponding to lower limit	0.00V–10.00V	0.00V	○
P06.19	AO1 output upper limit	P06.17 –100.0%	100.0%	○
P06.20	AO1 output corresponding to upper limit	0.00V–10.00V	10.00V	○
P06.21	AO1 output filter time	0.000s–10.000s	0.000s	○
P06.22	RO6 switch-on delay	0.000–50.000s	0.000s	○

Function code	Name	Description	Default	Modify
P06.23	RO6 switch-off delay	0.000–50.000s	0.000s	<input type="radio"/>
P06.27	RO4 switch-on delay	0.000–50.000s	0.000s	<input type="radio"/>
P06.28	RO4 switch-off delay	0.000–50.000s	0.000s	<input type="radio"/>
P06.29	AO1 analog output type selection	0: Voltage 1: Current Note: When switching the AO1 analog output type, it is necessary to ensure that the position of AO1 jumper cap on the main control board is correct. In addition, you need to modify P06.29, otherwise deviation may occur in the accuracy of the AO1 analog output.	0	<input type="radio"/>

P07 group HMI

Function code	Name	Description	Default	Modify
P07.00	User password	0–65535	0	<input type="radio"/>
P07.01	Function parameter copy	0: No operation 1: Uploading function parameters from the machine to keypad 2: Downloading function parameters (including the motor parameters) from the keypad to machine 3: Downloading function parameters (excluding motor parameters of the P02 and P12 groups) from the keypad to machine 4: Downloading function parameters (only motor parameters of the P02 and P12 groups) from the keypad to machine Note: After the parameter is set to 1, 2, 3 or 4, and the operation is executed, the parameter is automatically restored to 0.	0	<input checked="" type="radio"/>

Function code	Name	Description	Default	Modify
P07.02	Function of QUICK/JOG	0: No function 1: Jogging 2: Switch display status through the shifting key 3: Forward/reverse running switching 4: Clear the setting of UP/DOWN 5: Coast to stop 6: Switch running-command giving methods in sequence 7: Quick debugging mode (non-factory parameter debugging)	1	☉
P07.03	Sequence of switching running-command channels by pressing QUICK	0: Keypad→Terminal→Communication 1: Keypad←→Terminal 2: Keypad←→Communication 3: Keypad←→Communication	0	○
P07.04	Stop function selection of STOP/RST	0: Valid only for keypad control 1: Valid both for keypad and terminal control 2: Valid both for keypad and communication control 3: Valid for all control modes	0	○
P07.05	Selection 1 of parameters displayed in running state	0x0000–0xFFFF BIT0: Running frequency (Hz on) BIT1: Set frequency (Hz blinks) BIT2: Bus voltage (V on) BIT3: Output voltage (V on) BIT4: Output current (A on) BIT5: Running rotating speed (rpm on) BIT6: Output power (% on) BIT7: Output torque (% on) BIT8: PID reference value (% blinks) BIT9: PID feedback value (% on) BIT10: Input terminal state BIT11: Output terminal state BIT12: Torque setting value (% on) BIT13–BIT15: Reserved	0x03FF	○

Function code	Name	Description	Default	Modify
P07.06	Selection 2 of parameters displayed in running state	0x0000–0xFFFF BIT0: Analog P1- value (V on) BIT1–BIT3: Reserved BIT4: Motor overload percentage (% on) BIT5: VFD overload percentage (% on) BIT6: Ramp frequency reference value (Hz on) BIT7: Linear speed BIT8: AC incoming current BIT9–15: Reserved	0x0000	<input type="radio"/>
P07.07	Selection of parameters displayed in stopping state	0x0000–0xFFFF BIT0: Set frequency (Hz on, frequency blinks slowly) BIT1: Bus voltage (V on) BIT2: Input terminal state BIT3: Output terminal state BIT4: PID reference value (% blinks) BIT5: PID feedback value (% on) BIT6: Torque setting value (% on) BIT7: Analog P1- value (V on) BIT8–BIT15: Reserved	0x00FF	<input type="radio"/>
P07.08	Frequency display coefficient	0.01–10.00 Displayed frequency = Running frequency * P07.08	1.00	<input type="radio"/>
P07.09	Rotational speed display coefficient	0.1–999.9% Mechanical rotation speed = 120 * (Displayed running frequency) × P07.09 / (Number of motor pole pairs)	100.0%	<input type="radio"/>
P07.10	Linear speed display coefficient	0.1–999.9% Linear speed = (Mechanical rotation speed) × P07.10	1.0%	<input type="radio"/>
P07.11	Temperature of rectifier bridge module	0–100.0°C		<input checked="" type="radio"/>
P07.12	Temperature of inverter module	0–100.0°C		<input checked="" type="radio"/>

Function code	Name	Description	Default	Modify
P07.13	Software version of control board	1.00–655.35		●
P07.14	Accumulated running time	0–65535h		●
P07.15	High bit of power consumption of the VFD	0–65535 kWh (*1000)		●
P07.16	Low bit of power consumption of the VFD	0.0–999.9 kWh		●
P07.17	VFD model	0: G type		●
P07.18	Rated VFD power	0.4–3000.0kW		●
P07.19	Rated VFD voltage	50–1200V		●
P07.20	Rated VFD current	0.1–6000.0A		●
P07.21	Factory barcode 1	0x0000–0xFFFF		●
P07.22	Factory barcode 2	0x0000–0xFFFF		●
P07.23	Factory barcode 3	0x0000–0xFFFF		●
P07.24	Factory barcode 4	0x0000–0xFFFF		●
P07.25	Factory barcode 5	0x0000–0xFFFF		●
P07.26	Factory barcode 6	0x0000–0xFFFF		●
P07.27	Present fault type	0: No fault 1: Inverter unit U phase protection (OUt1) 2: Inverter unit V phase protection (OUt2)		●
P07.28	Last fault type	3: Inverter unit W phase protection (OUt3)		●

Function code	Name	Description	Default	Modify
P07.29	2nd-last fault type	4: Overcurrent at acceleration (OC1) 5: Overcurrent at deceleration (OC2) 6: Overcurrent at constant speed (OC3)		●
P07.30	3rd-last fault type	7: Overvoltage at acceleration (OV1) 8: Overvoltage at deceleration (OV2) 9: Overvoltage at constant speed (OV3)		●
P07.31	4th-last fault type	10: Bus undervoltage fault (UV) 11: Motor overload (OL1) 12: VFD overload (OL2)		●
P07.32	5th-last fault type	13: Phase loss on input side (SPI) 14: Phase loss on output side (SPO) 15: Rectifier module overheating (OH1) 16: Inverter module overheating (OH2) 17: External fault (EF) 18: RS485 communication fault (CE) 19: Current detection fault (ItE) 20: Motor autotuning fault (tE) 21: EEPROM operation fault (EEP) 22: PID feedback offline fault (PIDE) 23: Reserved 24: Running time reached (END) 25: Electronic overload (OL3) 26–29: Reserved 30: Input overvoltage (IOV) 31: Input undervoltage (IUV) 32: To-ground short circuit fault 1 (ETH1) 33: To-ground short circuit fault 2 (ETH2) 34: Speed deviation fault (dEu) 35: Mal-adjustment fault (STo) 36: Underload fault (LL) 37: Reserved 38: Phase sequence fault (PSF) 39: 3PH current imbalance of the fan (SPOF) 40: Fan overload (OLF) 41: Reserved 42: Expansion card Flash fault (E-FS) 43: Expansion card SPI communication disconnection (E-SPI)		●

Function code	Name	Description	Default	Modify
P07.33	Running frequency at present fault		0.00	●
P07.34	Ramp reference frequency at present fault		0.00	●
P07.35	Output voltage at present fault		0	●
P07.36	Output current at present fault		0.0	●
P07.37	Bus voltage at present fault		0.0	●
P07.38	Max. temperature at present fault		0.0	●
P07.39	Input terminal status at present fault		0	●
P07.40	Output terminal status at present fault		0	●
P07.41	Running frequency at last fault		0.00	●
P07.42	Ramp reference frequency at last fault		0.00	●
P07.43	Output voltage at last fault		0	●
P07.44	Output current at last fault		0.0	●
P07.45	Bus voltage at last fault		0.0	●
P07.46	Max. temperature at last fault		0.0	●
P07.47	Input terminal status at last fault		0.0	●

Function code	Name	Description	Default	Modify
P07.48	Output terminal status at last fault		0	●
P07.49	Running frequency at last fault		0	●
P07.50	Ramp reference frequency at 2nd-last fault		0.00	●
P07.51	Output voltage at 2nd-last fault		0	●
P07.52	Output current at 2nd-last fault		0	●
P07.53	Bus voltage at 2nd-last fault		0.0	●
P07.54	Max. temperature at 2nd-last fault		0.0	●
P07.55	Input terminal status at 2nd-last fault		0	●
P07.56	Output terminal status at 2nd-last fault		0	●

P08 group Enhanced functions

Function code	Name	Description	Default	Modify
P08.06	Running frequency of jog	0.0–P00.03 (max. output frequency)	10.00Hz	○
P08.07	ACC time for jogging	0.0–3600.0s	Model depended	○
P08.08	DEC time for jogging	0.0–3600.0s	Model depended	○
P08.15	Bus voltage pre-protection function	0–3	2	○

Function code	Name	Description	Default	Modify
P08.16	Low-voltage protection threshold	0.0V–2000.0V	300.0V	<input type="radio"/>
P08.17	Overvoltage pre-protection threshold	0.0V–2000.0V	780.0V	<input type="radio"/>
P08.18	Automatic restart delay	0.0–6000.0s	60.0s	<input type="radio"/>
P08.19	Low-voltage frequency limit running time	0.0–6000.0s	60.0s	<input type="radio"/>
P08.20	High-frequency current loop proportional gain	0–20000	1000	<input type="radio"/>
P08.21	High-frequency current loop integral time	0–20000	1000	<input type="radio"/>
P08.23	High-frequency current loop switching frequency	0.0–100.0% (max. output frequency P00.03)	100.0%	<input type="radio"/>
P08.25	Keypad lock enable	0: Do not lock keypad 1: Allow to lock keypad Lock: Press PRG key+DATA key simultaneously Unlock: Keep DATA key pressed down and then click V key by three times.	0	<input type="radio"/>
P08.26	Maintenance timing mode	0: No timing during sleep 1: Timing during sleep	0	<input type="radio"/>
P08.27	SM optimization mode selection	0: Enable Applicable to surface-mounted synchronous motors. The actual values of P02.21	1	<input type="radio"/>

Function code	Name	Description	Default	Modify
		(Direct-axis inductance of SM 1) and P02.22 (Quadrature-axis inductance of SM 1) are used in the calculation. 1: Disable Applicable to embedded/surface-mounted synchronous motors. The actual value of P02.21 (Direct-axis inductance of SM 1) is used in the calculation. Note: The optimization mode can be enabled/disabled according to the field on site.		
P08.28	Auto fault reset count 1	0–10	5	○
P08.29	Auto fault reset interval 1	0.1–3600.0s	5.0s	○
P08.30	Frequency decrease ratio in drop control	0.00–50.00Hz	0.00Hz	○
P08.32	FDT1 electrical level detection value	0.00–P00.03 (max. output frequency)	50.00Hz	○
P08.33	FDT1 lagging detection value	-100.0–100.0% (FDT1 electrical level)	5.0%	○
P08.34	FDT2 electrical level detection value	0.00–P00.03 (max. output frequency)	50.00Hz	○
P08.35	FDT2 lagging detection value	-100.0–100.0% (FDT2 electrical level)	5.0%	○
P08.36	Detection value for frequency being reached	0.0–P00.03 (max. output frequency)	0.00Hz	○
P08.39	Running mode of cooling fan	0: Common running mode 1: The fan keeps running after power-on 2: Control based on temperature	0	○
P08.40	PWM selection	0x00–0x21 LED ones: PWM mode selection 0: PWM mode 1, 3PH modulation and 2PH	01	◎

Function code	Name	Description	Default	Modify
		modulation 1: PWM mode 2, 3PH modulation LED tens: PWM low-speed carrier limit 0: Low-speed carrier limit mode 1 1: Low-speed carrier limit mode 2 2: No limit LED hundreds: Reserved		
P08.41	Overmodulation selection	0x00–0x11 LED ones: 0: Disable overmodulation 1: Enable overmodulation LED tens: 0: Mild overmodulation 1: Deepened overmodulation	01	⊙
P08.42	Keypad data control setting	0x000–0x1223 LED ones: Frequency enabling selection 0: Both \wedge/\vee key and digital potentiometer adjustments are valid 1: Only \wedge/\vee keys adjustment is valid 2: Only digital potentiometer adjustment is valid 3: Neither \wedge/\vee key nor digital potentiometer adjustment are valid LED tens: Frequency control selection 0: Valid only when P00.06=0 1: Valid for all frequency setting methods 2: Invalid for multi-step speed running when multi-step speed running has the priority LED hundreds: Action selection for stop 0: Setting is valid. 1: Valid during running, cleared after stop 2: Valid during running, cleared after a stop command is received LED thousands: \wedge/\vee keys and digital potentiometer integral function 0: The integral function is valid 1: The integral function is invalid	0x000	○

Function code	Name	Description	Default	Modify
P08.43	Integral time of digital potentiometer	0.01–10.00s	0.10s	○
P08.44	UP/DOWN terminal control setup	0x00–0x221 LED ones: Frequency enabling selection 0: UP/DOWN terminal setup is valid 1: UP/DOWN terminal setup is invalid LED tens: Frequency control selection 0: Valid only when P00.06=0 1: All frequency modes are valid 2: Invalid for multi-step speed when multi-step speed takes priority LED hundreds: Action selection during stop 0: Setting is valid. 1: Valid during running, cleared after stop 2: Valid during running, cleared after a stop command is received	0x000	○
P08.45	UP terminal frequency incremental change rate	0.01–50.00Hz/s	0.50Hz/s	○
P08.46	DOWN terminal frequency decremental change rate	0.01–50.00Hz/s	0.50Hz/s	○
P08.47	Action selection for frequency setup during power down	0x000–0x111 LED ones: Action selection at power-off during frequency adjusting through digitals. 0: Save the setting at power-off. 1: Clear the setting at power-off. LED tens: Action selection at power-off during frequency adjusting through Modbus communication 0: Save the setting at power-off. 1: Clear the setting at power-off. LED hundreds: Action selection at power-off during frequency adjusting through other communication	0x000	○

Function code	Name	Description	Default	Modify
		0: Save the setting at power-off. 1: Clear the setting at power-off.		
P08.48	High bit of initial value of power consumption	0–599999°(k)	0kWh	<input type="radio"/>
P08.49	Low bit of initial value of power consumption	0.0–999.9 kWh	0.0kWh	<input type="radio"/>
P08.50	Flux braking coefficient	0: Disable 100–150: A larger coefficient indicates a stronger brake intensity.	0	<input type="radio"/>
P08.51	VFD input power factor	0.00–1.00	0.56	<input type="radio"/>

P09 group PID control

Function code	Name	Description	Default	Modify
P09.00	PID reference source	0: Keypad digits (P09.01) 1: Analog P1- 2: Reserved 3: Analog P2- 4: Reserved 5: Multi-step 6: Modbus communication 7–9: Reserved 10: Pressure setting of dedicated function of air compressor	0	<input type="radio"/>
P09.01	PID reference preset through keypad	-100.0%–100.0%	0.0%	<input type="radio"/>
P09.02	PID feedback source	0: Analog P1- 1: Reserved 2: Analog P2- 3: Reserved 4: Modbus communication 5–7: Reserved 8: Pressure feedback of dedicated function of air compressor	0	<input type="radio"/>

Function code	Name	Description	Default	Modify
P09.03	PID output characteristics selection	0: PID output characteristic is positive: the feedback signal is larger than PID reference, which requires the VFD output frequency to decrease to balance PID, e.g. tension PID control of winding. 1: PID output characteristic is negative: feedback signal is larger than PID reference, which requires the VFD output frequency to increase to balance PID, e.g. tension PID control of unwinding.	0	<input type="radio"/>
P09.04	Proportional gain (Kp)	It determines the regulation intensity of the whole PID regulator, the larger the P is, the stronger the regulation intensity is. If this parameter is 100, it means the regulation amplitude made on output frequency command by the proportional regulator (ignoring integral and differential actions) is the max. frequency (P00.03) when the deviation between PID feedback quantity and reference quantity is 100%. Setting range: 0.00–100.00	10.00	<input type="radio"/>
P09.05	Integral time (Ti)	It determines the speed of integral regulation made on the deviation between PID feedback quantity and reference quantity by PID regulator. When the deviation between PID feedback quantity and reference quantity is 100%, the regulation quantity (ignoring proportional and differential actions) of integral regulator can reach max. output frequency (P00.03) through continuous regulation in the time set by P09.05. The shorter the integral time, the stronger the regulation intensity. Setting range: 0.00–10.00s	2.00s	<input type="radio"/>
P09.06	Differential time (Td)	It determines the intensity of variation regulation made on the deviation between PID feedback quantity and reference quantity by PID regulator. If the feedback quantity	1.00s	<input type="radio"/>

Function code	Name	Description	Default	Modify
		changes by 100% during the time set by P09.06, the regulation quantity of differential regulator (ignoring proportional and integral actions) is the max. output frequency (P00.03). The longer the differential time, the stronger the regulation intensity. Setting range: 0.00–10.00s		
P09.07	Sampling cycle (T)	It means the sampling cycle of feedback quantity. The regulator calculates once during each sampling cycle. The longer the sampling cycle, the slower the response speed. Setting range: 0.001–10.000s	0.100s	<input type="radio"/>
P09.08	Final limit of PID control deviation	It means the max. allowed deviation quantity of the PID system feedback value relative to closed-loop reference value. Within the deviation limit, PID regulator stops regulating, this parameter can be used to regulate the precision and stability of PID system. Setting range: 0.0–100.0%	0.1%	<input type="radio"/>
P09.09	Upper limit value of PID output	P09.10 –100.0% (max. frequency)	100.0%	<input type="radio"/>
P09.10	Lower limit value of PID output	-100.0%– P09.09 (max. frequency)	0.0%	<input type="radio"/>
P09.11	Feedback offline detection value	0.0–100.0%	0.0%	<input type="radio"/>
P09.12	Feedback offline detection time	0.0–3600.0s	1.0s	<input type="radio"/>
P09.13	PID regulation selection	0x00–0x11 LED ones: 0: Continue integral regulation when the frequency reaches upper/lower limit	0x01	<input type="radio"/>

Function code	Name	Description	Default	Modify
		1: Stop integral regulation when the frequency reaches upper/lower limit LED hundreds: 0: The same with the set direction 1: Contrary to the set direction		
P09.14	Differential filter times	0–60	2	<input type="radio"/>

P11 group Protection parameters

Function code	Name	Description	Default	Modify
P11.00	Phase loss protection	0x0000–0x1111 LED ones: 0: Disable input phase loss software protection 1: Enable input phase loss software protection Note: LED ones place detects input phase loss by phase sequence detection circuit. LED tens: 0: Disable output phase loss protection 1: Enable output phase loss protection LED hundreds: 0: Disable input phase loss hardware protection 1: Enable input phase loss hardware protection Note: LED hundreds place detects input phase loss by hardware detection circuit. LED thousands: 0: Disable phase sequence protection 1: Enable phase sequence protection	0x0110	<input type="radio"/>
P11.01	Frequency drop at transient power dip	0: Disable 1: Enable	0	<input type="radio"/>
P11.02	Frequency drop rate at transient power dip	0.00Hz– P00.03 /s (max. output frequency)	10.00Hz/s	<input type="radio"/>
P11.03	Overvoltage stall protection	0: Disable 1: Enable	1	<input type="radio"/>

Function code	Name	Description	Default	Modify
P11.04	Overvoltage stall protection voltage	120–150% (standard bus voltage) (380V)	140%	○
P11.05	Current limit selection	0x00–0x11 Ones: Current-limit action selection 0: Current-limit action is invalid 1: Current-limit action is always valid Tens: Hardware current-limit overload alarm selection 0: Hardware current-limit overload alarm is valid 1: Hardware current-limit overload alarm is invalid	01	◎
P11.06	Automatic current-limit level	50.0–200.0%	160.0%	◎
P11.07	Frequency drop rate at current limit	0.00–50.00Hz/s	10.00Hz/s	◎
P11.08	Pre-alarm selection for VFD/motor overload/underload	0x000–0x131 LED ones: 0: Motor overload/underload pre-alarm, relative to the motor rated current, 1: VFD overload/underload pre-alarm, relative to the VFD rated current LED tens: 0: The VFD keeps running after reporting an overload/underload alarm. 1: The VFD keeps running after reporting an underload alarm, but it stops running after reporting an overload alarm. 2: The VFD keeps running after reporting an overload alarm, but it stops running after reporting an underload alarm. 3: The VFD stops running after reporting an overload/underload alarm. LED hundreds: 0: Always detect 1: Detect only in constant speed running	0x000	○
P11.09	Overload pre-alarm detection level	P11.11–200%	G type: 150%	○

Function code	Name	Description	Default	Modify
P11.10	Overload pre-alarm detection time	0.1–3600.00s	1.0s	<input type="radio"/>
P11.11	Underload pre-alarm detection level	0%–P11.09	50%	<input type="radio"/>
P11.12	Underload pre-alarm detection time	0.1–3600.0s	1.0s	<input type="radio"/>
P11.13	Fault output terminal action during fault	0x00–0x11 LED ones: 0: Act during undervoltage fault 1: Do not act during undervoltage fault LED tens: 0: Act during automatic reset period 1: Do not act during automatic reset period	0x00	<input type="radio"/>
P11.14	Speed deviation detection value	0.0–50.0%	10.0%	<input type="radio"/>
P11.15	Speed deviation detection time	0.0–10.0s (Speed deviation protection is disabled when P11.15 is set to 0.0.)	0.5s	<input type="radio"/>
P11.16	Automatic frequency reduction during voltage drop	0: Invalid 1: Valid	1	<input type="radio"/>

P13 group Synchronous motor control parameters

Function code	Name	Description	Default	Modify
P13.00	Pull-in current reduction coefficient	0.0–100.0%	50.0%	<input type="radio"/>
P13.01	Initial magnetic pole detection mode	0: Do not detect 1: High-frequency superposition (reserved) 2: Pulse superposition (reserved)	0	<input checked="" type="radio"/>
P13.02	Pull-in current 1	0.0%–100.0% (of the rated current of the motor)	20.0%	<input type="radio"/>
P13.03	Pull-in current 2	0.0%–100.0% (of the rated current of the motor)	10.0%	<input type="radio"/>

Function code	Name	Description	Default	Modify
P13.04	Switching frequency of pull-in current	0.00Hz– P00.03 (max. output frequency)	30.00Hz	<input type="radio"/>
P13.05	High-frequency superposing frequency (reserved)	200Hz–1000Hz	500Hz	<input checked="" type="radio"/>
P13.06	High--frequency superposing voltage	0.0–300.0% (of the rated voltage of the motor)	40.0%	<input checked="" type="radio"/>
P13.08	Control parameter 1	0–FFFF	0x120	<input type="radio"/>
P13.09	Control parameter 2	0–300.00	5.00	<input type="radio"/>
P13.11	Maladjustment detection time	The function code is used to adjust the responsiveness of anti-maladjustment function. If the load inertia is large, increase the value of P13.11 properly, however, the responsiveness may slow down accordingly. Setting range: 0.0–10.0s	0.5s	<input type="radio"/>
P13.12	High-frequency compensation coefficient	The function code is valid when the motor speed exceeds the rated speed. If motor oscillation occurred, adjust this parameter properly. Setting range: 0.0–100.0%	50.0%	<input type="radio"/>
P13.13	Short-circuit braking current	0.0–150.0% (VFD)	0.0%	<input type="radio"/>
P13.14	Hold time of short-circuit braking for start	0.00–50.00s	0.00	<input type="radio"/>
P13.15	Hold time of short-circuit braking for stop	0.00–50.00s	0.00	<input type="radio"/>

P14 group Serial communication

Function code	Name	Description	Default	Modify
P14.00	Local communication address	1–247; 0 indicates a broadcast address	2	<input type="radio"/>
P14.01	Communication baud rate	0: 1200BPS 1: 2400BPS 2: 4800BPS 3: 9600BPS 4: 19200BPS 5: 38400BPS	4	<input type="radio"/>
P14.02	Data bit check	0: No parity check (N, 8, 1) for RTU 1: Even parity (E, 8, 1) for RTU 2: Odd parity (O, 8, 1) for RTU 3: No parity check (N, 8, 2) for RTU 4: Even parity (E, 8, 2) for RTU 5: Odd parity (O, 8, 2) for RTU	1	<input type="radio"/>
P14.03	Communication response delay	0–200ms	5ms	<input type="radio"/>
P14.04	Communication timeout time	0.0 (invalid); 0.1–60.0s	0.0s	<input type="radio"/>
P14.05	Transmission error processing	0: Alarm and coast to stop 1: Do not alarm and continue running 2: Do not alarm and stop as per stop mode (under communication control mode only) 3: Do not alarm and stop as per stop mode (under all control modes)	0	<input type="radio"/>
P14.06	Communication processing action	0x00–0x11 LED ones: write operation action 0: Respond to write operations 1: Not respond to write operations LED tens: Communication encryption processing 0: Communication encryption setting is invalid 1: Communication encryption setting is valid	0x00	<input type="radio"/>

P17 group Status viewing

Function code	Name	Description	Default	Modify
P17.00	Set frequency	0.00Hz– P00.03	0.00Hz	●
P17.01	Output frequency	0.00Hz– P00.03	0.00Hz	●
P17.02	Ramp reference frequency	0.00Hz– P00.03	0.00Hz	●
P17.03	Output voltage	0–1200V	0V	●
P17.04	Output current	0.0–3000.0A	0.0A	●
P17.05	Motor speed	0–65535RPM	0 RPM	●
P17.06	Torque current	-3000.0–3000.0A	0.0A	●
P17.07	Excitation current	-3000.0–3000.0A	0.0A	●
P17.08	Motor power	-300.0%–300.0% (relative to rated motor power)	0.0%	●
P17.09	Output torque	-250.0–250.0%	0.0%	●
P17.10	Estimated motor frequency	0.00– P00.03	0.00Hz	●
P17.11	DC bus voltage	0.0–2000.0V	0V	●
P17.12	Digital input terminal status	0000–00FF	0	●
P17.13	Digital output terminal status	0000–000F	0	●
P17.16	Master fault code	0–43 (see P07.27–P07.32 for details)	0	●
P17.17	Reserved	0–1000	0	●
P17.18	Auto fault reset count of present fault	0–20	0	●
P17.19	P1- input voltage	Display analog input voltage value of P1-channel, 2.00V–10.00V corresponds to 4–20mA; P05.32–P05.34 correspond to pressure 0.0– P18.04 . If P1- input voltage is larger than 9.8V or less than 1V, it indicates pressure signal fault occurs. Range: 0.00–10.00V	0.00V	●

Function code	Name	Description	Default	Modify
P17.20	PT1 input voltage	Display analog input voltage value of PT1 channel. Under air-compressor mode, connect to PT100 thermal resistor temperature sensor, different temperature generates different resistor value, and different resistor value corresponds to different input voltages, therefore, the input voltage value can correspond to corresponding detection temperature. Input voltage P18.28 – P18.29 corresponds to -20°C to +150°C. Setting range: 0.00–10.00V	0.00V	●
P17.21	P2- input voltage	Display analog input voltage value of P2-channel, 2.00V–10.00V correspond to 4–20mA; P05.42 – P05.44 correspond to pressure 0.0– P18.38 . When the input voltage of P2- is larger than 9.8V or less than 1V, it indicates pressure signal fault occurs. Setting range: 0.00–10.00V	0.00V	●
P17.22	PT2 input voltage	Display analog input voltage value of PT2 channel. Under air-compressor mode, connect to PT100 thermal resistor temperature sensor, different temperature generates corresponding resistor value, and different resistor value corresponds to corresponding input voltage, therefore, input voltage value can correspond to corresponding detection temperature. Input voltage P18.32 – P18.33 correspond to -20°C to +150°C. Setting range: 0.00–10.00V	0.00V	●
P17.23	PID reference value	Display the set value of discharge pressure signal. 100% corresponds to the upper limit value of discharge pressure sensor (P18.04) (if P18.37 =1, 100% corresponds to P18.38). Setting range: -100.0–100.0%	0.0%	●
P17.24	PID feedback value	Display the detection value of discharge pressure signal.	0.0%	●

Function code	Name	Description	Default	Modify
		Setting range: -100.0–100.0%		
P17.25	Motor power factor	-1.00–1.00	0.0	●
P17.26	Current running time	0–65535m	0m	●
P17.28	ASR controller output	-300.0%–300.0% (of the motor rated current)	0.0%	●
P17.29	Magnetic pole angle of SM	0.0–360.0	0.0	●
P17.30	Phase compensation quantity of SM	-180.0–180.0	0.0	●
P17.31	High-frequency superposition current of SM	0.0%–200.0%	0.0	●
P17.32	Flux linkage	0.0%–200.0%	0.0	●
P17.33	Exciting current reference	-3000.0–3000.0A	0.0	●
P17.34	Torque current reference	-3000.0–3000.0A	0.0	●
P17.35	AC incoming current	0.0–5000.0A	0.0	●
P17.36	Output torque	-3000.0Nm–3000.0Nm	0.0Nm	●
P17.37	Motor overload count value	0–100 (OL1 fault is reported when the count value reaches 100)	0	●
P17.38	PID output value	Display the output value of PID control of discharge pressure signal; 100% corresponds to max. output frequency P00.03 . Setting range: -100.00–100.00%	0.00%	●
P17.39	Warning code	The warning code is the same as P07.27–P07.31. This warning code is generally used in conjunction with P25 group Fault policy functions to display a VFD pre-warning signal	0	●

Function code	Name	Description	Default	Modify
		while the keypad TRIP indicator flashes. The warning code only acts as a warning prompt, and does not lead to failure shutdown.		
P17.40	Status of expansion card	0: No card 1: IO card	0	●
P17.41	Software version of expansion card	0.00–655.35	0.00	●

P18 group Functions for air compressors

Function code	Name	Description	Default	Modify
P18.00	Air compressor control mode	0: Invalid 1: Air-compressor control mode 2: Water-lubricated air compressor control mode Note: When P18.00 is set to a non-zero value, P19 group (Air compressor status viewing) is valid.	0	◎
P18.01	Sleep function selection	0: Invalid 1: Sleep mode 1 2: Sleep mode 2 Note: When sleep function is valid and unloading conditions are fulfilled, the VFD decelerates to P18.12 [no-load running frequency], and then, if discharge pressure is larger than P18.06 [loading pressure] during the time set by P18.13 [no-load delay], the VFD will decelerate to P01.15 [stop speed] and then coast to stop to enter sleep stage. If the discharge pressure is less than loading pressure during P18.13 , the VFD will perform loaded running again, and pressure PID will regulate accordingly.	1	◎
P18.02	Loading/unloading mode	0: Automatic; 1: Manual When setting to manual state, after air compressor starts, loading/unloading manually; when setting to automatic mode,	0	○

Function code	Name	Description	Default	Modify
		the air compressor loads/unloads automatically after starting.		
P18.03	Temperature sensor channel	0: Machine head temperature PT 1, auxiliary temperature PT2 1: Machine head temperature PT 2, auxiliary temperature PT1 2: Both of temperature PT1 and PT2 are displayed (valid only when P18.00=0)	1	☉
P18.04	Upper limit of pressure sensor P1	0.00–20.00 Mpa Related to the actual range of pressure sensor, the corresponding voltage of P18.04 is P05.34 . Note: When restoring to default value, this value stays in currently set value.	1.60Mpa	☉
P18.05	Unloading pressure	Under automatic loading/unloading mode, when air compressor control is valid and the air compressor supplies air as normal, if the discharge pressure is higher than P18.05 ,	0.80Mpa	○
P18.06	Loading pressure	unloading automatically. If sleep function is valid (P18.01 =1), the VFD enters sleep state; if the discharge pressure is lower than P18.06 , loading automatically. P18.07 is used to set the air-supply pressure when the air compressor runs stably. During load-carrying running, the motor speed is controlled by pressure PID, and the system keeps the discharge pressure constant via adjusting master speed. See 5.2 for details on pressure control process logic.	0.60Mpa	○
P18.07	Set pressure	Setting range: 0.00– P18.04	0.70Mpa	○
P18.08	Starting temperature of the fan	When the machine head temperature is higher than P18.08 , the fan starts.	75℃	○
P18.09	Stopping temperature of the fan	When the machine head temperature is lower than P18.09 , the fan stops. P18.10 is used to set the target temperature of the machine head when the air	65℃	○

Function code	Name	Description	Default	Modify
P18.10	Setting temperature	compressor runs stably, the fan speed is controlled by thermostatic PID (P18.42 =0), PID calculation is carried out via P18.10 and the machine head temperature to realize thermostatic control. Setting range: -20–150	75℃	<input type="radio"/>
P18.11	Lower-limit frequency at load-carrying running	P18.12–P00.04 (upper limit of running frequency) During regulating, if the pressure exceeds the set working pressure but lower than the unloading pressure, the allowed min. working frequency is P18.11.	40.00Hz	<input type="radio"/>
P18.12	No-load running frequency	P01.15–P18.11 (lower-limit frequency of load-carrying running) The output working frequency allowed during no-load of air compressor.	38.00 Hz	<input type="radio"/>
P18.13	No-load delay	When sleep function is valid, after unloading, the VFD runs at no-load frequency in the time set by P18.13 , and then enters sleep state. When air consumption quantity is small, users can enable sleep function; if sleep function is valid, it is necessary to lower down P18.13 to make the device enter sleep state quicker. Setting range: 0–3600s	300s	<input type="radio"/>
P18.14	Stopping delay	After the stopping command becomes valid, the VFD will first run at no-load frequency in the time set by P18.14 , and then stops. Setting range: 0–3600s	0s	<input type="radio"/>
P18.15	Loading delay	Loading operation is available only after the motor runs at no-load frequency in the time set by P18.15 . Setting range: 0–3600s	10s	<input type="radio"/>
P18.16	Restarting delay	After the system stops, it is necessary to wait until the time set by P18.16 elapsed before restart.	30s	<input type="radio"/>

Function code	Name	Description	Default	Modify
		Setting range: 0–3600s		
P18.17	Pre-alarm pressure	When current discharge pressure is higher than P18.17 , the system indicates pressure pre-alarm by setting BIT8 of P19.13 to 1.	0.90Mpa	<input type="radio"/>
P18.18	Alarm pressure	When current discharge pressure is higher than P18.18 , the system indicates pressure alarm by setting BIT10 of P19.13 to 1, and emergency-stop will be applied. Setting range: 0.00– P18.04	1.00Mpa	<input type="radio"/>
P18.19	Pre-alarm temperature	When machine head temperature is higher than P18.19 , the system indicates temperature pre-alarm by setting BIT9 of P19.13 to 1.	105℃	<input type="radio"/>
P18.20	Alarm temperature	When the machine head temperature is higher than P18.20 , the system indicates temperature alarm by setting BIT11 of P19.13 to 1, and emergency-stop will be applied.	110℃	<input type="radio"/>
P18.21	Low-temperature protection threshold	When machine head temperature is lower than P18.21 , the system indicates low-temperature pre-alarm by setting BIT14 of P19.13 to 1, and air compressor cannot start. Setting range: -20–150	-10℃	<input type="radio"/>
P18.22	Power calibration coefficient	It is used to calibrate the displayed value of P19.10 [actual motor output power]. Setting range: 0%–200%	100%	<input type="radio"/>
P18.23	Temperature PID calculation cycle (Ts)	Set the sampling cycle of temperature PID. Setting range: 0.0–10.0s	2.0s	<input type="radio"/>
P18.24	Gain coefficient (kp)	It determines the regulation intensity of temperature PID regulator, the larger the value of kp, the stronger the regulation intensity, however, if it is too large, temperature oscillation may occur, users can fine-tune based on the default value. Setting range: 0.0–100.0	18.0	<input type="radio"/>

Function code	Name	Description	Default	Modify
P18.25	Convergence coefficient (K)	It determines the converging speed of temperature PID regulator, the larger the value of K, the stronger the converging intensity, however, if it is too large, temperature oscillation may occur, users can fine-tune based on the default value. Setting range: 0.00–1.00	0.12	<input type="radio"/>
P18.26	Upper limit of temperature PID	It is used to limit the output value of temperature PID, of which 100% corresponds to max. output frequency	100.00%	<input type="radio"/>
P18.27	Lower limit of temperature PID	(P00.03) of fan. Setting range: 0.00–100.00%	10.00%	<input type="radio"/>
P18.28	PT1 calibration voltage 1 (20°C)	It is used to calibrate temperature detection circuit before shipment. Connect to the resistor whose resistance is the same with that of PT100 at 20°C, read the voltage value of P17.20 and input it to P18.28 .	3.41V	<input type="radio"/>
P18.29	PT1 calibration voltage 2 (120°C)	Connect to the resistor whose resistance is the same with that of PT100 at 120°C, read the voltage value of P17.20 and input it to P18.29 . Setting range: 0.00–10.00V Note: This value will stay in currently set value when restoring to default values.	7.42V	<input type="radio"/>
P18.30	Pressure drop value of upper limit frequency	0.00– P18.04 When current pressure is larger than this pressure value, decrease the upper limit frequency as per the set value of P18.31 .	0.70Mpa	<input type="radio"/>
P18.31	Drop rate of upper limit frequency	0.00Hz–10.00Hz When current pressure is larger than the pressure drop value of upper limit frequency, this value is the reduction quantity of the corresponding upper limit frequency at every additional 0.01Mpa.	0.00Hz	<input type="radio"/>

Function code	Name	Description	Default	Modify
P18.32	PT2 calibration voltage 1 (20°C)	It is used to calibrate temperature detection circuit before shipment. Connect to the resistor whose resistance is the same with that of PT100 at 20°C, read the voltage value of P17.22 and input it to P18.32 .	3.41V	<input type="radio"/>
P18.33	PT2 calibration voltage 2 (120°C)	Connect to the resistor whose resistance is the same with that of PT100 at 120°C, read the voltage value of P17.22 and input it to P18.33 . Setting range: 0.00–10.00V Note: 1. This value will stay in currently set value when restoring to default values. 2. PT2 is on the expansion card, so P18.32 and P18.33 make sense only when an expansion card is connected. If no expansion card is connected, both parameters are 0.	7.42V	<input type="radio"/>
P18.34	Auxiliary temperature protection enabling	0: Disable 1: Enable	0	<input checked="" type="radio"/>
P18.35	Auxiliary temperature pre-alarm	-20–150 When P18.34 is enabled and auxiliary temperature is higher than P18.35 , the system indicates auxiliary temperature pre-alarm by setting BIT8 of P19.14 to 1.	105°C	<input type="radio"/>
P18.36	Auxiliary temperature alarm	-20–150 When P18.34 is enabled and auxiliary temperature is higher than P18.36 , the system indicates auxiliary temperature alarm by setting BIT10 of P19.14 to 1, and emergency-stop will be applied.	110°C	<input type="radio"/>
P18.37	Pressure sensor channel	0: Discharge pressure P1, auxiliary pressure P2 1: Discharge pressure P2, auxiliary pressure P1	0	<input checked="" type="radio"/>

Function code	Name	Description	Default	Modify
		2: Both of pressure P1 and P2 are displayed (valid only when P18.00=0)		
P18.38	Upper limit of pressure sensor P2	0.00–20.00 Mpa It is related to the actual range of pressure sensor, the corresponding voltage of P18.04 is P05.44 . Note: When restoring to default values, the value will stay in current value.	1.60Mpa	☉
P18.39	Auxiliary pressure protection enabling	0: Disable 1: Enable	0	☉
P18.40	Auxiliary pressure pre-alarm	0.00–20.00 When P18.39 is enabled and the auxiliary pressure is larger than P18.40, the system indicates auxiliary pressure pre-alarm by setting BIT7 of P19.14 to 1.	0.90Mpa	○
P18.41	Auxiliary pressure alarm	0.00–20.00 When P18.39 is enabled and the auxiliary pressure is larger than P18.41, the system indicates pressure alarm by setting BIT9 of P19.14 to 1, and emergency stop will be applied.	1.00Mpa	○
P18.42	Fan frequency reference mode	0: Temperature PID 1: Analog P2- setting 2: RS485 communication	0	☉
P18.43	Fan control mode	0: Air compressor mode, the power-frequency fan starts/stops as per the temperature; 1: Terminal, the power-frequency fan starts/stops via terminals; 2: 485 communication (address 0X201B, write 1 to start, write 3 to stop)	0	☉
P18.44	Automatic frequency reduction threshold	0–120% Add automatic frequency reduction function. When the output current is larger than automatic frequency reduction threshold, it will adjust the output frequency via regulator	120%	○

Function code	Name	Description	Default	Modify
		to ensure the running current of the master is below the automatic frequency reduction threshold.		
P18.45	Maintenance timeout time	0–8000h When it is set to “0”, maintenance timeout function will be invalid. When it is set to a non-zero value, after parts maintenance pre-alarm is reported, if the VFD continues working until exceeding the value set by P18.45, the system will report maintenance timeout pre-alarm, and BIT11 of P19.14 will be set to “1”.	0	<input type="radio"/>
P18.46	Input overvoltage threshold	0–2000V	484V	<input type="radio"/>
P18.47	Input undervoltage threshold	0–2000V	250V	<input type="radio"/>

P19 group Air compressor status viewing

Function code	Name	Description	Default	Modify
P19.00	The set time of maintenance on part 1	P19.00–P19.04 displays the set time of maintenance on five kinds of parts. If the accumulated running time of the part exceeds the corresponding set value, the BIT of P19.14 will be set to 1 to indicate pre-alarms; if it is set to “0”, the running time pre-alarm will be invalid. P19.05–P19.09 displays the running time of corresponding parts.	0	<input checked="" type="radio"/>
P19.01	The set time of maintenance on part 2		0	<input checked="" type="radio"/>
P19.02	The set time of maintenance on part 3		0	<input checked="" type="radio"/>
P19.03	The set time of maintenance on part 4		0	<input checked="" type="radio"/>

Function code	Name	Description	Default	Modify
P19.04	The set time of maintenance on part 5		0	●
P19.05	Running time of part 1		0	●
P19.06	Running time of part 2		0	●
P19.07	Running time of part 3		0	●
P19.08	Running time of part 4		0	●
P19.09	Running time of part 5		0	●
P19.10	Actual output power of the motor	Display output power of the motor, it can be calibrated by P18.22 . Range: 0.0–6553.5kW	0.0kW	●
P19.11	Present pressure	<p>Display the discharge pressure value detected currently.</p> <p>Range: 0.00–655.35Mpa</p>	0.00Mpa	●
P19.12	Present temperature	Display the machine head temperature detected currently.	0°C	●

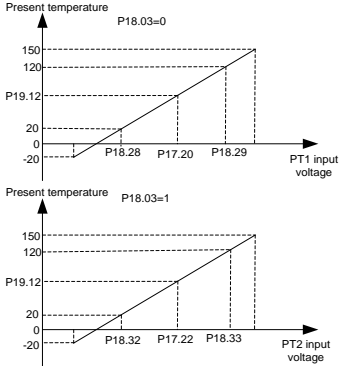
Function code	Name	Description	Default	Modify
		 <p>Present temperature P18.03=0</p> <p>Present temperature P18.03=1</p> <p>Range: -20~150°C</p>		
P19.13	Signal state 1	<p>0000~0xFFFF</p> <p>BIT0: Air filter blockage signal 1: Fault; 0: Normal</p> <p>BIT1: Oil filter blockage signal 1: Fault; 0: Normal</p> <p>BIT2: Separator blockage signal 1: Fault; 0: Normal</p> <p>BIT3: Precision splitter blockage signal 1: Fault; 0: Normal</p> <p>BIT4: External fault signal 1 1: Fault; 0: Normal</p> <p>BIT5: External fault signal 2 1: Fault; 0: Normal</p> <p>BIT6: Solenoid valve signal state 1: Load; 0: Unload</p> <p>BIT7: Fan state 1: Run; 0: Stop</p> <p>BIT8: Pressure pre-alarm signal 1: Pressure pre-alarm; 0: Normal</p> <p>BIT9: Temperature pre-alarm signal 1: Temperature pre-alarm; 0: Normal</p> <p>BIT10: Pressure alarm signal 1: Pressure alarm; 0: Normal</p> <p>BIT11: Temperature alarm signal 1: Temperature alarm; 0: Normal</p>	0	●

Function code	Name	Description	Default	Modify
		BIT12: Pressure signal 1: Pressure signal fault; 0: Normal BIT13: Temperature signal 1: Temperature signal fault; 0: Normal BIT14: Low-temperature protection 1: Low-temperature alarm; 0: Normal BIT15: Master state 1: Run; 0: Stop		
P19.14	Signal state 2	0–0xFFFF BIT0: Maintenance reminder of part 1 1: Maintenance required; 0: Normal BIT1: Maintenance reminder of part 2 1: Maintenance required; 0: Normal BIT2: Maintenance reminder of part 3 1: Maintenance required; 0: Normal BIT3: Maintenance reminder of part 4 1: Maintenance required; 0: Normal BIT4: Maintenance reminder of part 5 1: Maintenance required; 0: Normal BIT5: Auxiliary pressure signal 1: Auxiliary pressure signal fault; 0: Normal BIT6: Auxiliary temperature signal 1: Auxiliary temperature signal fault; 0: Normal BIT7: Auxiliary pressure pre-alarm signal 1: Pressure pre-alarm; 0: Normal BIT8: Auxiliary temperature pre-alarm signal 1: Temperature pre-alarm; 0: Normal BIT9: Auxiliary pressure alarm signal 1: Pressure alarm; 0: Normal BIT10: Auxiliary temperature alarm signal 1: Temperature alarm; 0: Normal BIT11: Maintenance timeout remainder 1: Maintenance timeout remainder; 0: Normal BIT12: Phase sequence remainder 1: Fault; 0: Normal BIT13: Reserved BIT14: PTC overtemperature signal 1: PTC overtemperature alarm; 0: Normal	0	●

Function code	Name	Description	Default	Modify
		BIT15: Emergency stop signal 1: Emergency stop signal alarm, 0: Normal		
P19.15	Device state	0: Standby 1: Run 2: Fault 3: Emergency stop 4: Undervoltage 5: Alarm 6: Sleep 7: In stopping 8: Restart delay	0	●
P19.16	Accumulated running time	Display range: 0–65535h	0	●
P19.17	Accumulated load-carrying running time		0	●
P19.18	Restart count-down	Display the remaining time of restart delay. After the system stops, it will enter restart delay state and restart count-down to prevent immediate restart. After restart delay time is up, the system enters standby state. Under standby state, start command can be received. Setting range: 0–3600s	0s	●
P19.19	Output value of temperature PID	Display the output value of temperature PID regulation of machine head, 100% corresponds to max. output frequency (P00.03) of the fan. Setting range: 0.00–100.00%	0.00%	●
P19.20	Present auxiliary pressure	Display the auxiliary pressure value detected at present.	0.00Mpa	●

Function code	Name	Description	Default	Modify
		<p>Present auxiliary pressure Mpa</p> <p>Range: 0.00–655.35Mpa</p>		
P19.21	Present auxiliary temperature	<p>Display the auxiliary temperature value detected at present.</p> <p>Range: -20–150°C</p>	0°C	●
P19.22	Input power phase sequence state	<p>If the VFD enables phase sequence detection and input phase loss hardware protection, corresponding fault will be reported when negative sequence and any phase loss occurs; otherwise, fault will not be reported. 0: Positive sequence</p>	0	●

Function code	Name	Description	Default	Modify
		1: Negative sequence 2: Phase loss		
P19.23	Input power voltage	0-2000V	0	●

P20 group Function for water lubrication

Function code	Name	Description	Default	Modify
P20.00	Water lubrication mode selection	0-4 0: Automatic 1: Replenish water manually 2: Discharge water manually 3: Change water manually 4: Cut off water manually	0	○
P20.01	Starting detection time of water lubrication	0-65535 Unit: s	60	○
P20.02	Reserved	0-65535 Unit: s	0	○
P20.03	Time for replenishing water	0-65535 Unit: s	1000	○
P20.04	Time for discharging water	0-65535 Unit: s	1000	○
P20.05	Times of changing water	0-65535	3	○
P20.06	Time for changing water	0-65535 Unit: h	200	○
P20.07	Status bit 1 of water lubrication	BIT0: Flag bit for extra low water level BIT1: Flag bit for low water level BIT2: Flag bit for medium/high water level BIT3: Flag bit for extra high water level BIT4: Flag bit for replenishing water BIT5: Flag bit for discharging water BIT6: Flag bit for cutting off water BIT7: Flag bit for changing water	0	●

Function code	Name	Description	Default	Modify
		BIT8: Changing and discharging water to medium water level BIT9: Changing and replenishing water to medium water level BIT10: Changing and replenishing water to high water level BIT11: Changing and discharging water to low water level BIT12: Flag bit for water heating BIT13: Flag bit for abnormal water level BIT14: Water replenishing delay alarm BIT15: Water discharging delay alarm		
P20.08	Starting temperature of water heater valve	-20~150℃	5	<input type="radio"/>
P20.09	Stopping temperature of water heater valve	-20~150℃	20	<input type="radio"/>
P20.10	Alarm temperature of low ambient environment	-20~150℃	0	<input type="radio"/>

P21 group Power-frequency fan protection

Function code	Name	Description	Default	Modify
P21.00	Rated current of the fan	0.0~40.0A This function code is related to current detection and overload protection function of power-frequency fan. If P21.00 is set to a non-zero value, this function is enabled. If P21.00 is set to 0, this function is disabled.	0.0A	<input type="radio"/>
P21.01	Current transformation ratio of the fan	1.0~4000.0	200 (≤15kW); 1000 (≥18.5kW)	<input type="radio"/>

Function code	Name	Description	Default	Modify
P21.03	Current imbalance coefficient	1.00–3.00 Among the current of three phases of the fan, if the ratio between max. current and min. current is larger than P21.03 , the VFD displays fan current imbalance fault.	1.60	<input type="radio"/>
P21.04	Calibration coefficient of A phase current of the fan	0.0–150.0% Actual current = Displayed current * current calibration coefficient Note: When restoring to default values, this value will stay in currently set value.	100.0%	<input type="radio"/>
P21.05	Calibration coefficient of B phase current of the fan		100.0%	<input type="radio"/>
P21.06	Calibration coefficient of C phase current of the fan		100.0%	<input type="radio"/>
P21.10	Alternative frequency	0.0–100.0% (max. output frequency)	50.0%	<input type="radio"/>
P21.11	Running time of alternative frequency	0.0–6000.0s Note: When P25 group Fault policy is selected to be 1, after a fault occurs to the VFD, the VFD continues running at alternative frequency (P21.10). If the fault persists for the time larger than that of P21.11, the VFD coasts to stop. If the fault no longer occurs during P21.11, the VFD automatically restores to normal mode.	60.0s	<input type="radio"/>
P21.13	Display current of A phase of the fan	0.0–40.0A	0.0A	<input checked="" type="radio"/>

Function code	Name	Description	Default	Modify
P21.14	Display current of B phase of the fan	0.0–40.0A	0.0A	●
P21.15	Display current of C phase of the fan	0.0–40.0A	0.0A	●
P21.16	Sampling value of A phase current zero drift	0–4095	0	●
P21.17	Sampling value of B phase current zero drift	0–4095	0	●
P21.18	Sampling value of C phase current zero drift	0–4095	0	●
P21.20	Fan state	0X0000–0XFFFF Bit0: When it is 1, it indicates that power-frequency fan is started	0x0000	●

P25 group Fault policy

Function code	Name	Description	Default	Modify
P25.00	User-defined fault action selection 1	0–0x6666 Ones: Inverter unit U phase protection (OUt1) Tens: Inverter unit V phase protection (OUt2) Hundreds: Inverter unit W phase protection (OUt3) Thousands: Overcurrent at acceleration (OC1) For details about P25 group fault policy function, see section 5.3 “Fault policy function description”.	0x0000	○

Function code	Name	Description	Default	Modify
P25.01	User-defined fault action selection 2	0-0x6666 Ones: Overcurrent at deceleration (OC2) Tens: Overcurrent at constant speed (OC3) Hundreds: Overvoltage at acceleration (OV1) Thousands: Overvoltage at deceleration (OV2)	0x0000	<input type="radio"/>
P25.02	User-defined fault action selection 3	0-0x6666 Ones: Overvoltage at constant speed (OV3) Tens: Bus undervoltage fault (UV) Hundreds: Motor overload (OL1) Thousands: VFD overload (OL2)	0x0020	<input type="radio"/>
P25.03	User-defined fault action selection 4	0-0x6666 Ones: Phase loss on input side (SPI) Tens: Phase loss on output side (SPO) Hundreds: Reserved Thousands: Inverter module overheating (OH2)	0x0002	<input type="radio"/>
P25.04	User-defined fault action selection 5	0-0x6666 Ones: External fault (EF) Tens: RS485 communication fault (CE) Hundreds: Current detection fault (ItE) Thousands: Motor autotuning fault (tE)	0x0020	<input type="radio"/>
P25.05	User-defined fault action selection 6	0-0x6666 Ones: EEPROM operation fault (EEP) Tens: PID feedback sensor offline (PIDE) Hundreds: Reserved Thousands: Running time reached (END)	0x0020	<input type="radio"/>
P25.06	User-defined fault action selection 7	0-0x6666 Ones: Electronic overload (OL3) Tens: Reserved Hundreds: Reserved Thousands place: Reserved	0x0002	<input type="radio"/>
P25.07	User-defined fault action selection 8	0-0x6666 Ones: Reserved Tens: Input overvoltage (IOV) Hundreds: Input undervoltage (IUUV) Thousands: To-ground short circuit fault 1 (ETH1)	0x0220	<input type="radio"/>

Function code	Name	Description	Default	Modify
P25.08	User-defined fault action selection 9	0-0x6666 Ones: To-ground short circuit fault 2 (ETH2) Tens: Speed deviation fault (dEu) Hundreds: Mal-adjustment fault (STo) Thousands: Underload fault (LL)	0x5200	○
P25.09	User-defined fault action selection 10	0-0x6666 Ones: Reserved Tens: Phase sequence fault (PSF) Hundreds: 3PH current imbalance of the fan (SPOF) Thousands: Fan overload (OLF)	0x2440	○
P25.10	User-defined fault action selection 11	0-0x6666 Ones: Reserved Tens: Expansion card Flash fault (E-FS) Hundreds: Expansion card SPI communication disconnection (E-SPI) Thousands: Reserved	0x0000	○
P25.13	Auto fault reset count 2	0-20	5	○
P25.14	Auto fault reset interval 2	0.1-3600.0s	10.0s	○

5.2 Control logic of the air compressor

(1) The following figure shows the control logic of the air compressor.

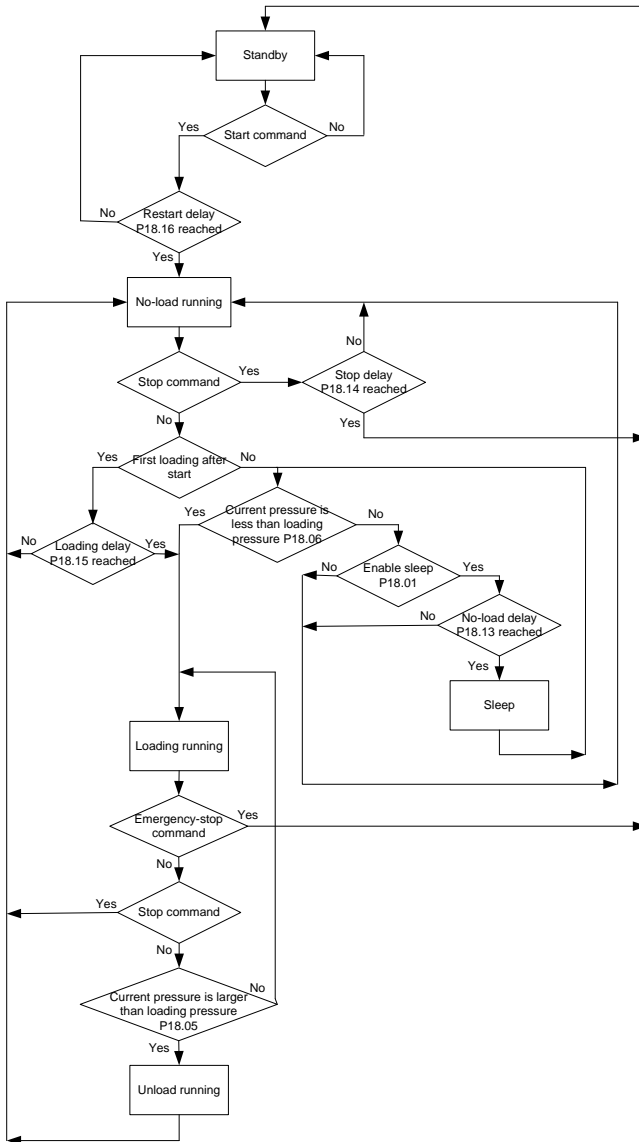

(2) The following figure shows the pressure and running frequency control during the running of the air compressor.

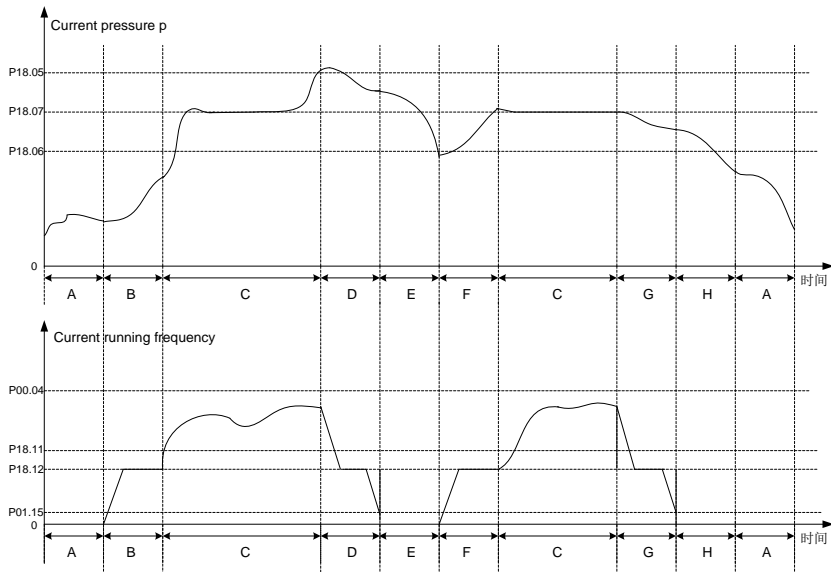

In above figure, P18.05 is unloading pressure; P18.06 is loading pressure; P18.07 is the set pressure. P00.04 is upper limit frequency, P18.11 is lower limit value of load-carrying running frequency, P18.12 is no-load frequency, P01.15 is stop speed. Description of A-H stage control process is shown below:

A: Standby state

B: Starting stage of startup, duration is P18.15 (including part of the acceleration time P00.11);

C: Constant discharge stage of loading, pressure PID regulation is valid;

D: Unloading stage, duration includes part of deceleration time P00.12 and P18.13;

E: Sleep stage, the VFD does not run;

F: Starting stage of wake-up, duration is P18.15 (including part of the acceleration time P00.11);

G: Starting stage of stop, duration includes part of deceleration time P00.12 and P18.14;

H: Restart delay stage after stop, duration is P18.16.

When air compressor control is valid and under automatic loading/unloading mode, the air compressor enters normal air supply state after starts. When the discharge pressure is higher than P18.05, automatic unloading will be applied, and the VFD enters sleep state. If sleep function is invalid, the VFD will continue running at no-load frequency P18.12. When the discharge pressure is lower than P18.06, automatic loading will be applied, and during load-carrying running, the master

speed is controlled by pressure PID. P18.07 is used to set the air supply pressure when the air compressor runs stably. The VFD keeps the discharge pressure constant by regulating the master speed. Constant-pressure control adopts PID algorithm, and the frequency reference source of the master is set by P00.06=7, the PID reference source selects P09.00 = 10, reference pressure is set via P18.07. The feedback source of PID P09.02 = 8, which is obtained by detecting the pressure signal. PID parameter P9.04, P9.05 and P9.06 adopts system default values.

Note: In above figure, the VFD stops as per P01.08, default setting is decelerate to stop.

Normal stop command and unloading stage are deceleration process; the VFD will change to coast to stop during emergency-stop operation and faults.

5.3 Fault policy function description

Table 5-1 Fault policy functions

Fault policy function selection	Meaning
0	Coast to stop when a fault occurs, and manual reset is required.
1	Run at alternative frequency when a fault occurs. <ul style="list-style-type: none"> ◇ If the VFD is in the stopping state, a fault is reported, and manual reset is required. ◇ If the VFD is in the running state, it runs at the alternative frequency (P21.10). If the fault disappears within the running time of alternative frequency (P21.11), the VFD restores to normal operation. ◇ If the VFD continues running at alternative frequency (P21.10), and the fault persists after P21.11 is reached, a fault is reported, and the VFD coasts to stop. Manual reset is required. ◇ During running at the alternate frequency, the warning code P17.39 is displayed, and the keypad TRIP indicator flashes.
2	Coast to stop when a fault occurs, and automatic reset is allowed. <ul style="list-style-type: none"> ◇ When a fault occurs, the VFD will attempt to reset itself every interval (P08.29). If the fault disappears, the VFD restores to normal operation. ◇ During auto reset, no fault is reported, but the warning code (P17.39) is displayed, and the keypad TRIP indicator flashes. ◇ The fault is reported only when the cumulative number of automatic reset times exceeds the number set in P08.28, and a manual reset is required. ◇ The cumulative number of automatic reset times is displayed on P17.18. ◇ After the fault is successfully reset and the VFD operates normally

Fault policy function selection	Meaning
	for more than 10 minutes, the VFD will automatically clear the cumulative number of automatic resets times (P17.18). ◇ If you press the RST key during auto fault reset, auto fault reset is stopped forcibly, and the number of automatic fault reset times (P17.18) is cleared.
3	Same functions as above 2. ◇ The difference is that the function codes for the number of auto fault reset times and the auto fault reset interval are different. P25.13 and P25.14 are for policy 3 while P08.28 and P08.29 are for policy 2. ◇ It allows the user to select different automatic fault reset times and intervals for different faults in some special situations.
4	Do not deal with the fault during operation when a fault occurs. ◇ Troubleshooting only during downtime ◇ If a fault occurs during operation, the fault is not be reported and the VFD still operates normally, but the warning code (P17.39) is displayed and the keypad TRIP light flashes.
5	After a fault occurs, no fault is reported, and only a warning is given. ◇ When the VFD is in the stopping or running state, if a fault occurs, no fault is reported, only a warning code (P17.39) is displayed, and the keypad TRIP indicator flashes.
6	Directly shield the fault when a fault occurs. ◇ When a fault occurs, neither a fault nor a warning code is reported, and the keypad TRIP indicator does not flash.

Table 5-2 Factory default fault policies

Item	Fault	Factory default fault policy functions							
		0	1	2	3	4	5	6	
0	No fault	/	/	/	/	/	/		
1	Inverter unit U phase protection (OUt1)	✓							
2	Inverter unit V phase protection (OUt2)	✓							
3	Inverter unit W phase protection (OUt3)	✓							
4	Overcurrent at acceleration (OC1)	✓							

Item	Fault	Factory default fault policy functions							
		0	1	2	3	4	5	6	
5	Overcurrent at deceleration (OC2)	✓							
6	Overcurrent at constant speed (OC3)	✓							
7	Overvoltage at acceleration (OV1)	✓							
8	Overvoltage at deceleration (OV2)	✓							
9	Overvoltage at constant speed (OV3)	✓							
10	Bus undervoltage fault (UV)			✓					
11	Motor overload (OL1)	✓							
12	VFD overload (OL2)	✓							
13	Phase loss on input side (SPI)			✓					
14	Phase loss on output side (SPO)	✓							
15	Reserved	✓							
16	Inverter module overheating (OH2)	✓							
17	External fault (EF)	✓							
18	RS485 communication fault (CE)			✓					
19	Current detection fault (ItE)	✓							
20	Motor autotuning fault (tE)	✓							
21	EEPROM operation fault (EEP)	✓							
22	PID feedback sensor offline (PIDE)			✓					
23	Reserved	✓							
24	Running time reached (END)	✓							
25	Electronic overload (OL3)			✓					
26	Reserved	✓							
27	Reserved	✓							
28	Reserved	✓							
29	Reserved	✓							

Item	Fault	Factory default fault policy functions						
		0	1	2	3	4	5	6
30	Input overvoltage (IOV)			✓				
31	Input undervoltage (IUV)			✓				
32	To-ground short-circuit fault 1 (ETH1)	✓						
33	To-ground short-circuit fault 2 (ETH2)	✓						
34	Speed deviation fault (dEu)	✓						
35	Mal-adjustment fault (STo)			✓				
36	Underload fault (LL)							✓
37	Reserved	✓						
38	Phase sequence fault (PSF)						✓	
39	3PH current imbalance of the fan (SPOF)						✓	
40	Fan overload (OLF)			✓				
41	Reserved	✓						
42	Expansion card Flash fault (E-FS)	✓						
43	Expansion card SPI communication disconnection (E-SPI)	✓						

6 Fault information and fault handling

6.1 VFD faults and solutions

Fault contents and solutions for GD300-01A VFD are shown below.

Fault code	Fault type	Possible cause	Solution
OUt1	Inverter unit U phase protection	<ul style="list-style-type: none"> Acceleration is too fast. Internal damage occurs to the IGBT of this phase. Misacts caused by interference. Drive wires are connected improperly. Short-circuited to ground. 	<ul style="list-style-type: none"> Increase acceleration time. Replace power unit. Check the drive wires. Check whether peripheral equipment suffers from strong interference source.
OUt2	Inverter unit V phase protection		
OUt3	Inverter unit W phase protection		
OV1	Overvoltage at acceleration	<ul style="list-style-type: none"> Input voltage is abnormal. There is large energy feedback. 	<ul style="list-style-type: none"> Check the input power. Check if the deceleration time of the load is too short or the motor starts during the rotating, or dynamic brake units needs to be installed.
OV2	Overvoltage at deceleration		
OV3	Overvoltage at constant speed		
OC1	Overcurrent at acceleration	<ul style="list-style-type: none"> Acceleration or deceleration is too fast. Grid voltage is too low. VFD power is too low. Load transients or is abnormal. Short-circuited to ground, output phase loss. There is strong external interference. 	<ul style="list-style-type: none"> Increase acceleration /deceleration time. Check the input power. Adopt the VFD with a larger power. Check if the load is short circuited (short circuited to ground or between wires) or stall occurs. Check the output wiring. Check if there is strong interference.
OC2	Overcurrent at deceleration		
OC3	Overcurrent at constant speed		
UV	Bus undervoltage fault	Grid voltage is too low.	Check the grid input power.
OL1	Motor overload	<ul style="list-style-type: none"> Grid voltage is too low. Rated current of the motor is set improperly. Motor stalls or load transients. 	<ul style="list-style-type: none"> Check grid voltage. Reset rated current of the motor. Check load and adjust torque boost quantity.

Fault code	Fault type	Possible cause	Solution
OL2	VFD overload	<ul style="list-style-type: none"> • Acceleration is too fast. • The motor is restarted during rotating. • Grid voltage is too low. • The load is too large. 	<ul style="list-style-type: none"> • Increase acceleration time. • Restart the motor after stop. • Check grid voltage. • Adopt the VFD with a larger power. • Select a proper motor.
SPI	Phase loss on input side	Phase loss or fluctuation occurs to input R, S and T.	<ul style="list-style-type: none"> • Check input power. • Check installation wiring.
SPO	Phase loss on output side	Phase loss output occurs to U, V and W (or serious 3PH imbalance occurs to the load).	<ul style="list-style-type: none"> • Check the output wiring. • Check the motor and cable.
OH1	Rectifier module overheating	<ul style="list-style-type: none"> • Air duct blocked or fan damaged. • Ambient temperature is too high. • Long-time overload running. 	<ul style="list-style-type: none"> • Ventilate the air duct or replace the fan. • Lower down the ambient temperature.
OH2	Inverter module overheating		
EF	External fault	S external fault input terminal acts.	Check external equipment input.
CE	RS485 communication fault	<ul style="list-style-type: none"> • Baud rate is set improperly. • Communication line fault. • Communication address error. • Communication suffers strong interference. 	<ul style="list-style-type: none"> • Set proper baud rate. • Check the wiring of communication interfaces. • Set correct communication address. • Replace or change the wiring to improve anti-interference capacity.
ItE	Current detection fault	<ul style="list-style-type: none"> • Poor contact of controller board connector. • Hall components are damaged. • Amplifying circuit is abnormal. 	<ul style="list-style-type: none"> • Check the connector and re-plug wires. • Replace the hall. • Replace the main control board.
tE	Motor autotuning fault	<ul style="list-style-type: none"> • Motor capacity does not match VFD capacity. 	<ul style="list-style-type: none"> • Change the VFD model. • Set motor type and

Fault code	Fault type	Possible cause	Solution
		<ul style="list-style-type: none"> • Motor parameters are set improperly. • The deviation between the parameters obtained from autotuning and the standard parameter is huge. • Autotuning timeout. 	<ul style="list-style-type: none"> nameplate parameters correctly. • Empty the motor load and identify again. • Check the motor wiring and parameter setup. • Check whether upper limit frequency is larger than 2/3 of the rated frequency.
EEP	EEPROM operation error	<ul style="list-style-type: none"> • Error occurred to the writing/reading of control parameters. • EEPROM damaged. 	<ul style="list-style-type: none"> • Press STOP/RST to reset. • Replace the main control board.
PIDE	PID feedback offline fault	<ul style="list-style-type: none"> • PID feedback offline. • PID feedback source disappears 	<ul style="list-style-type: none"> • Check PID feedback signal wire. • Check PID feedback source
END	Running time reached	The actual running time of the VFD is larger than the internally set time.	<ul style="list-style-type: none"> • Ask supplier for help. • Adjust the set running time.
OL3	Electronic overload fault	The VFD reports overload pre-alarm according to the set value.	Check the load and overload pre-alarm threshold.
IOV	Input overvoltage	Input grid overvoltage. Input overvoltage threshold (P18.46) is set improperly.	<ul style="list-style-type: none"> • Check the input grid power supply. • Check the installation and wiring. • Ensure the setting value of P18.46 is proper.
IUV	Input undervoltage	Input grid undervoltage. Input undervoltage threshold (P18.47) is not set improperly.	<ul style="list-style-type: none"> • Check the input grid power supply. • Check the installation and wiring. • Ensure the setting value of P18.47 is proper.
ETH1	To-ground short-circuit fault 1	<ul style="list-style-type: none"> • VFD output is short circuited to ground. • Current detection circuit is 	<ul style="list-style-type: none"> • Check whether motor wiring is normal/motor is short circuited to ground.

Fault code	Fault type	Possible cause	Solution
ETH2	To-ground short-circuit fault 2	faulty. • Actual motor power setup differs sharply from the VFD power.	<ul style="list-style-type: none"> • Replace the hall. • Replace main control board/drive board. • Reset correct motor parameters.
dEu	Speed deviation fault	Load is too heavy or stall.	<ul style="list-style-type: none"> • Check the load and ensure it is normal, increase the detection time. • Check whether control parameters are proper.
STo	Mal-adjustment fault	<ul style="list-style-type: none"> • Control parameters of synchronous motor is set improperly. • Autotuning parameters are inaccurate. • VFD is not connected to the motor. 	<ul style="list-style-type: none"> • Check the load and ensure the load is normal. • Check whether control parameters are set correctly. • Increase maladjustment detection time.
LL	Electronic underload fault	The VFD reports underload pre-alarm according to the set value.	Detect the load and underload pre-alarm threshold.
PSF	Phase sequence fault	The phase sequence on power input side is negative.	Swop any two of the power input cables.
SPOF	3PH current imbalance of the fan	<ul style="list-style-type: none"> • Phase loss occurs to the connection of three phases of the fan. • Stator winding of three phases of the fan is abnormal. • The quality of the power grid is poor. 	<ul style="list-style-type: none"> • Check whether the fan wiring is disconnected or poorly contacted. • Measure whether the impedance of the three-phase winding of the fan is balanced. • Increase the set value properly in P21.03 to reduce the sensitivity of the imbalance judgment.
OLF	Fan overload	<ul style="list-style-type: none"> • Rated fan current is set improperly. • Fan power is too small. • Fan stalls. 	<ul style="list-style-type: none"> • Check whether the set value of P21.00 is the same with the rated current of the fan nameplate, and whether

Fault code	Fault type	Possible cause	Solution
			<p>the current transformation ratio (P21.01) is the same with current transformer nameplate.</p> <ul style="list-style-type: none"> • Actually detected fan current is too large, it is recommended to increase the power. • Check whether the fan stalls.
E-FS	Expansion card Flash fault	R/W error occurred to the calibration parameters. The expansion card Flash is damaged.	Press STOP/RST to reset. Replace the main control board.
E-SPI	Expansion card communication offline	There is no data transmission between the expansion card and the main control board.	Check whether the pin header between the expansion card and the main control board is loosened or disconnected.
	Touch screen communication interrupted	485 communication port is disconnected.	Check whether communication line is loosened.

6.2 Fault contents and solutions of air compressor equipment

Abnormal state and solutions of air compressor equipment:

P19.13	State type	Possible cause	Solution
BIT0=1	Air filter blocked	Air filter is abnormal.	Check air filter after stop.
BIT1=1	Oil filter blocked	Oil filter is abnormal.	Check oil filter after stop.
BIT2=1	Separator blocked	Separator is abnormal.	Check the separator after stop.
BIT3=1	Precision splitter blocked	Precision splitter is abnormal.	Check the precision splitter after stop.
BIT8=1	Pressure pre-alarm	Actual voltage is detected by P1 to be larger than the pre-alarm voltage set by P18.17.	<ul style="list-style-type: none"> • Check whether solenoid valve is normal. • Check whether pressure control parameters are set correctly.

P19.13	State type	Possible cause	Solution
BIT9=1	Temperature pre-alarm	Actual temperature detected by PT1 is higher than the pre-alarm temperature set by P18.19.	<ul style="list-style-type: none"> • Check whether fan control parameters are set correctly. • Whether the fan operates normally. • Fan power is too small to dissipate heat effectively. • Check whether there is lubricating oil.
BIT10=1	Pressure alarm	Actual voltage detected by P1 is larger than the alarm voltage set by P18.18.	<ul style="list-style-type: none"> • Check whether solenoid valve is normal. • Check whether pressure control parameters are set correctly.
BIT11=1	Temperature alarm	Actual temperature detected by PT1 is higher than the alarm temperature set by P18.20.	<ul style="list-style-type: none"> • Check whether fan control parameters are correct. • Whether fan operates normally. • Fan power is too small to dissipate heat effectively. • Check whether there is lubricating oil.
BIT12=1	Pressure signal fault	The actual voltage is detected by P1 to be less than 1V.	<ul style="list-style-type: none"> • Pressure detection sensor is abnormal. • Pressure detection input P1 signal wire is disconnected. • Pressure signal interface does not select current signal.
BIT13=1	Temperature signal fault	PT100 sensor is disconnected.	<ul style="list-style-type: none"> • Check whether the wiring of PT100 is normal. • Check whether temperature detection sensor is abnormal. • Temperature detection input circuit is abnormal.
BIT14=1	Low-temperature protection pre-alarm	The actual temperature detected by PT1 is less than the low temperature	<ul style="list-style-type: none"> • Temperature detection sensor is abnormal. • Temperature detection input

P19.13	State type	Possible cause	Solution
		protection threshold set by P18.21.	<p>circuit is abnormal.</p> <ul style="list-style-type: none"> Actual temperature is too low, and low -temperature pre-alarm is reported accordingly, and therefore the air compressor cannot start.

P19.14	State type	Possible cause	Solution
BIT0=1	Part 1 needs maintenance	The running time of part 1 exceeds the time set by P19.00.	Carry out maintenance after stop
BIT1=1	Part 2 needs maintenance	The running time of part 2 exceeds the time set by P19.01.	Carry out maintenance after stop
BIT2=1	Part 3 needs maintenance	The running time of part 3 exceeds the time set by P19.02.	Carry out maintenance after stop
BIT3=1	Part 4 needs maintenance	The running time of part 4 exceeds the time set by P19.03.	Carry out maintenance after stop
BIT4=1	Part 5 needs maintenance	The running time of part 5 exceeds the time set by P19.04.	Carry out maintenance after stop
BIT5=1	Auxiliary pressure signal fault	The actual voltage detected by P2 is less than 1V.	<ul style="list-style-type: none"> Pressure detection sensor is abnormal. Pressure detection input P2 signal wire is disconnected.
BIT6=1	Auxiliary temperature signal fault	PT100 sensor is disconnected.	<ul style="list-style-type: none"> Check whether the wiring of PT100 is normal. Temperature detection sensor is abnormal. Temperature detection input circuit is abnormal.

P19.14	State type	Possible cause	Solution
BIT7=1	Auxiliary pressure pre-alarm	The actual voltage detected by P2 is larger than the pre-alarm pressure set by P18.17.	<ul style="list-style-type: none"> Pressure detection sensor is abnormal. The pressure is set to a too large value. Adjust pressure PID regulator.
BIT8=1	Auxiliary temperature pre-alarm	The actual temperature detected by PT2 is larger than the pre-alarm temperature set by P18.19.	<ul style="list-style-type: none"> Temperature detection sensor is abnormal. Temperature detection input circuit is abnormal, if not calibrated. The starting temperature of the fan is set to a too high value. The temperature of the fan is set to a too high value. Fan power is too small to dissipate heat effectively.
BIT9=1	Auxiliary pressure alarm	The actual voltage detected by P2 is larger than the alarm pressure set by P18.18.	<ul style="list-style-type: none"> Pressure detection sensor is abnormal. The voltage is set to a too high value. Adjust pressure PID regulator.
BIT10=1	Auxiliary temperature alarm	The actual temperature detected by PT2 is higher than the alarm temperature set by P18.20.	<ul style="list-style-type: none"> Temperature detection sensor is abnormal. Temperature detection input circuit is abnormal, if not calibrated. The starting temperature of the fan is set to a too high value. The temperature of the fan is set to a too high value. The fan power is too small to dissipate heat effectively.
BIT11=1	Maintenance timeout alarm	Any part whose running time exceeds the set value will	Carry out maintenance on the timeout parts after stop.

P19.14	State type	Possible cause	Solution
		enter overtime maintenance stage, and hereafter, if the running time exceeds the time set by P18.45 again, maintenance timeout alarm will be reported.	

Appendix A Product dimensions

A.1 Keypad diagram



A.2 External keypad installation dimensions

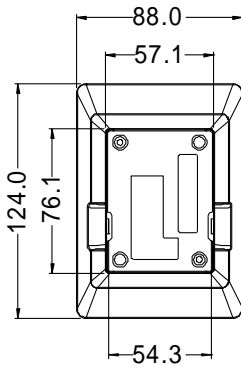

Simple keypad bracket
(61006-00911)

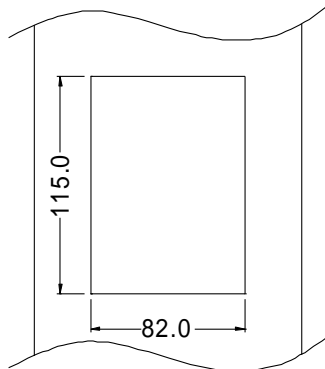

Customer installation
dimensions

A.3 Wall installation dimensions of 380V–440V VFDs

For VFDs of AC 3PH 380V (-15%)–440V (+10%)

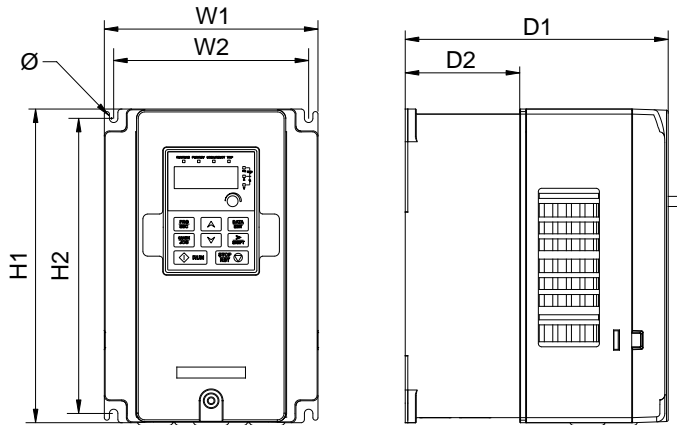

Figure A-1 Wall installation diagram for 380V 7.5kW–37kW VFD models

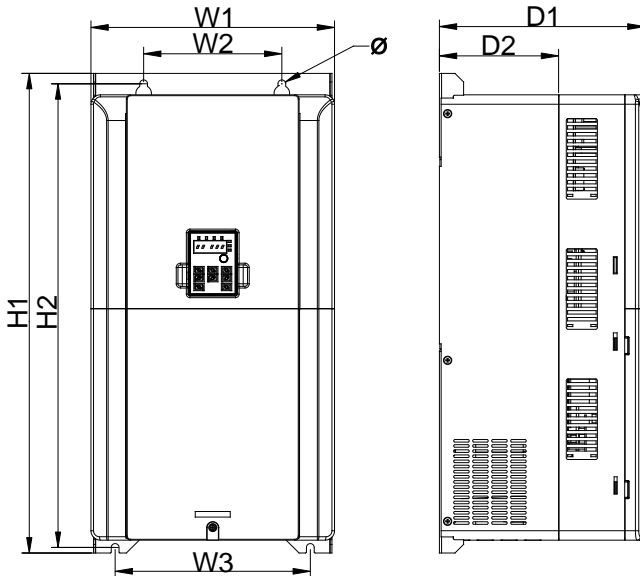

Figure A-2 Wall installation diagram for 380V 45kW–55kW VFD models

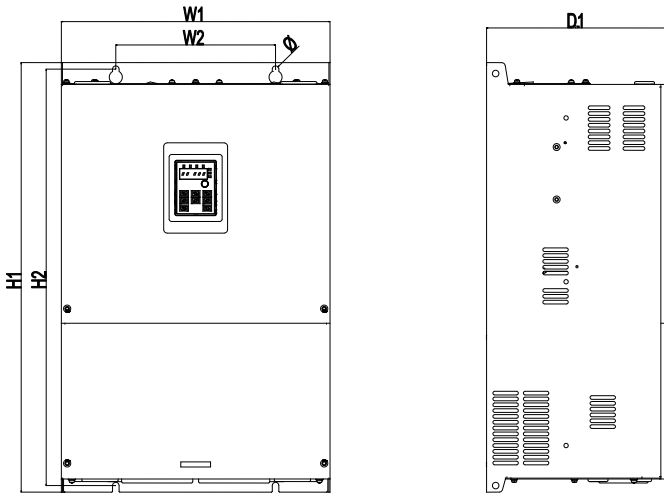

Figure A-3 Wall installation diagram for 380V 75kW VFD models

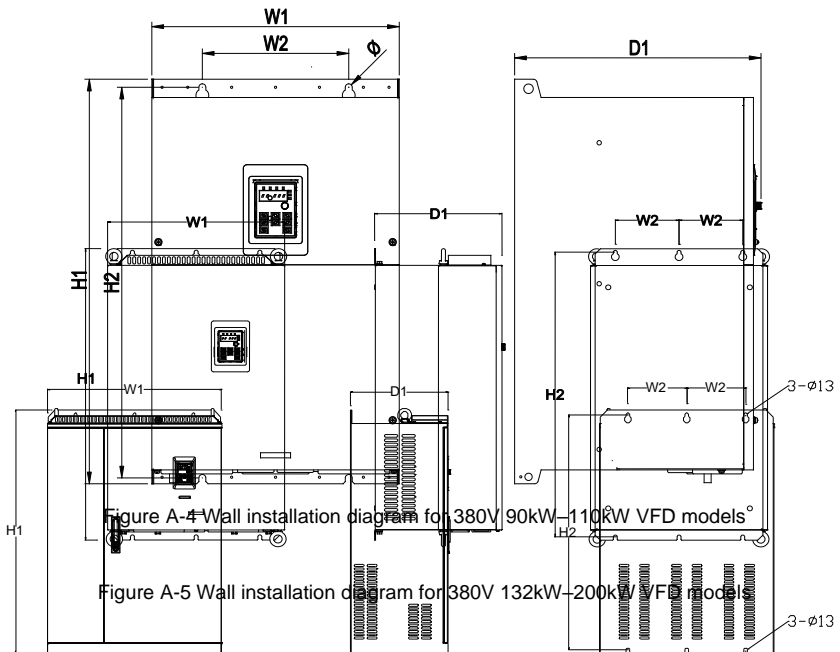

Figure A-4 Wall installation diagram for 380V 90kW-110kW VFD models

Figure A-5 Wall installation diagram for 380V 132kW-200kW VFD models

Figure A-6 Wall installation diagram for 380V 220kW–350kW VFD models

Table A-1 Wall installation dimension of 7.5kW–315kW single VFDs (unit: mm)

Power	W1	W2	W3	H1	H2	D1	D2	Diameter of mounting hole	Screw specification
7.5kW	170	151	—	320	303.5	196.5	113	6	M5
11kW–22kW	200	185	—	340.5	328.5	184.5	104.5	6	M5
30kW–37kW	250	230	—	400	380	202	123.5	6	M5
45kW–55kW	282	160	226.0	560	542	238	138	9	M8
75kW	370	220	—	590	572	250	---	9	M8
90kW–110kW	338	200	—	554	535	337	—	9.5	M8
132kW–200kW	500	180	—	870	850	360	—	11	M10
220kW–350kW	680	230	—	960	926	380	—	13	M12

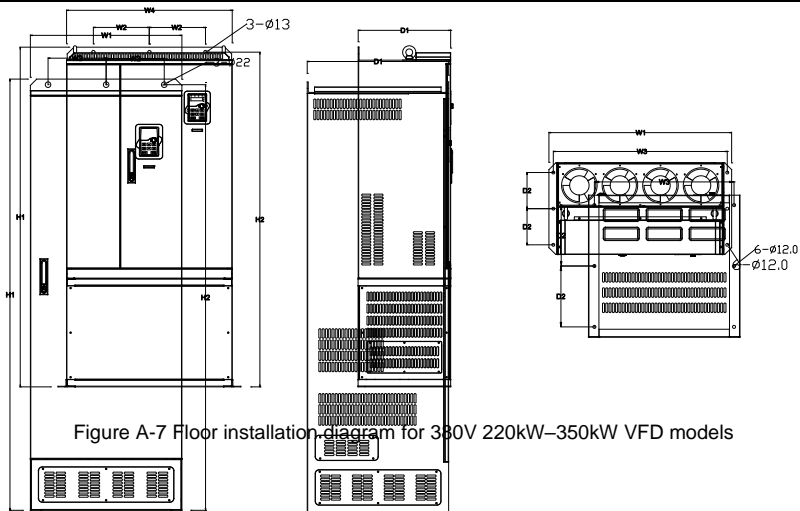

Figure A-7 Floor installation diagram for 380V 220kW–350kW VFD models

Figure A-8 Floor installation diagram for 380V 220kW–500kW VFD models

Table A-2 Wall installation dimension of 220kW–500kW single VFDs (unit: mm)

Power	W1	W2	W3	W4	H1	H2	D1	D2	Diameter of mounting hole	Screw specification
220kW–350kW	750	230	714	680	1410	1390	380	150	13/12	M10

400kW–500kW	620	230	573	/	1700	1678	560	240	22\12	M10
-------------	-----	-----	-----	---	------	------	-----	-----	-------	-----

A.4 Flange installation dimensions of 380V–440V VFDs

For VFDs of AC 3PH 380V (-15%)–440V (+10%)

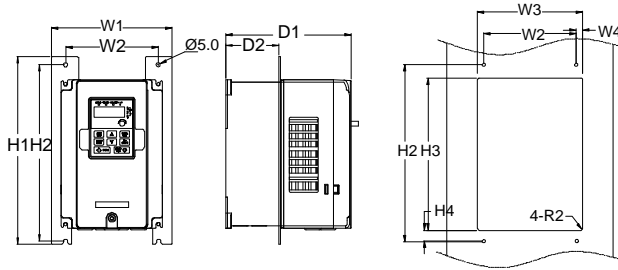

Figure A-9 Flange installation diagram for 380V 7.5kW–55kW VFD models

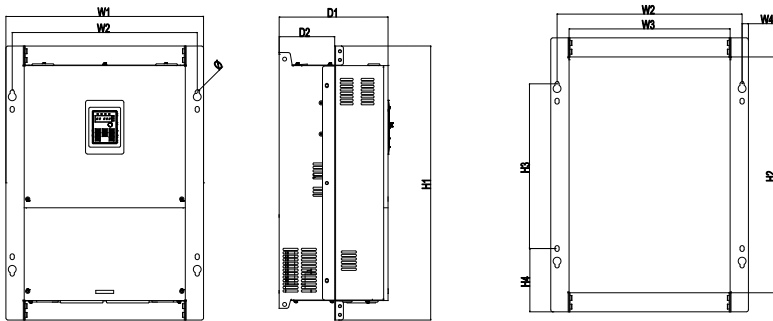

Figure A-10 Flange installation diagram for 380V 7.5kW VFD models

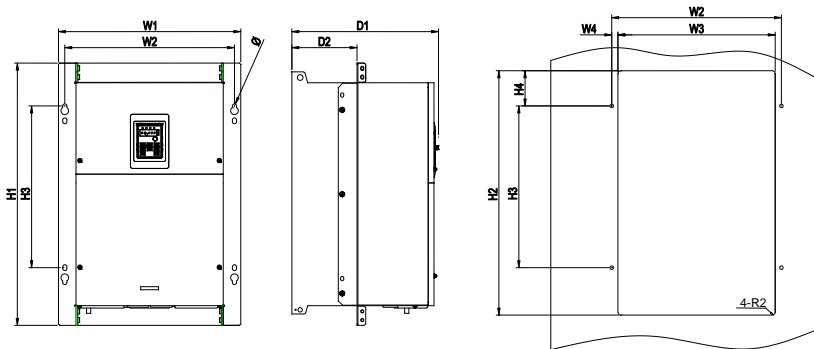

Figure A-11 Flange installation diagram for 380V 90kW–110kW VFD models

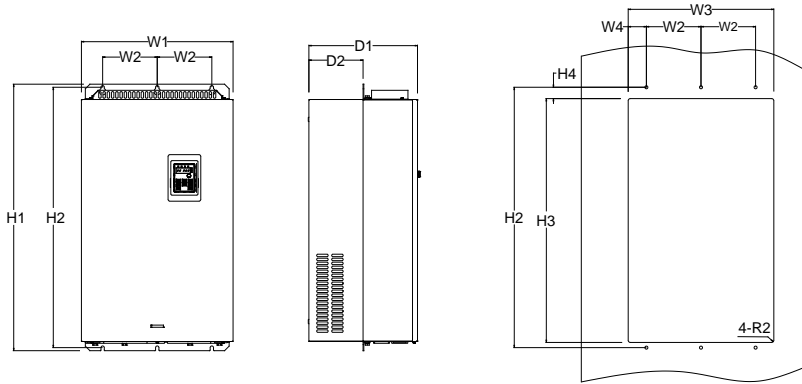

Figure A-12 Flange installation diagram for 380V 132kW–200kW VFD models

Table A-3 Flange installation dimension of 380V 7.5kW–200kW VFD models (unit: mm)

Power	W1	W2	W3	W4	H1	H2	H3	H4	D1	D2	Diameter of mounting hole	Screw specification
7.5kW	191	151	174	11.5	370	351	324	12	196.5	113	6	M5
11kW–22kW	266	250	224	13	371	250	350.5	20.5	184.5	104	6	M5
30kW–37kW	316	300	274	13	430	300	410	55	202	118.5	6	M5
45kW–55kW	352	332	306	13	580	400	570	80	238	134	9	M8
75kW	454	425	370	14.5	632	544	380	146	250	127.5	9.5	M8
90–110kW	418	389	361	14	600	559	370	80	337	150	9.5	M8
132kW–200kW	500	180	480	60	870	850	796	37	358	178.5	11	M10

Note: Flange mounting plates are often required for flange installation. For 132–200kW models, you can move the upper and lower mounting beams to the middle position but not use flange mounting plates. Floor installation but not flange installation is recommended for 220kW and higher models.

A.5 Wall installation dimensions of 520V–690V VFDs

For VFDs of AC 3PH 520V (-15%)–690V (+10%)

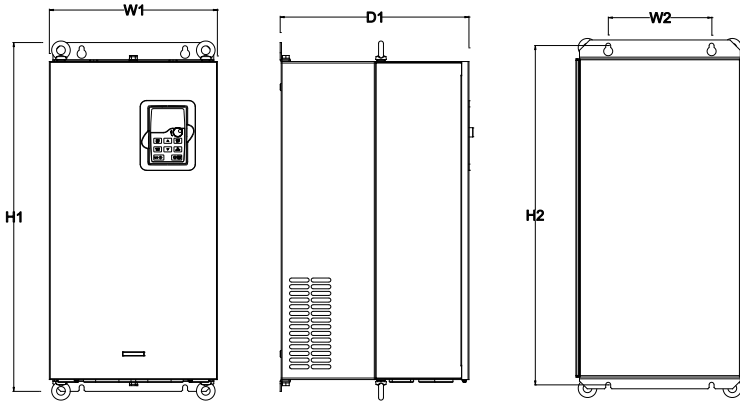

Figure A-13 Wall installation diagram for 660V 22kW–132kW VFD models

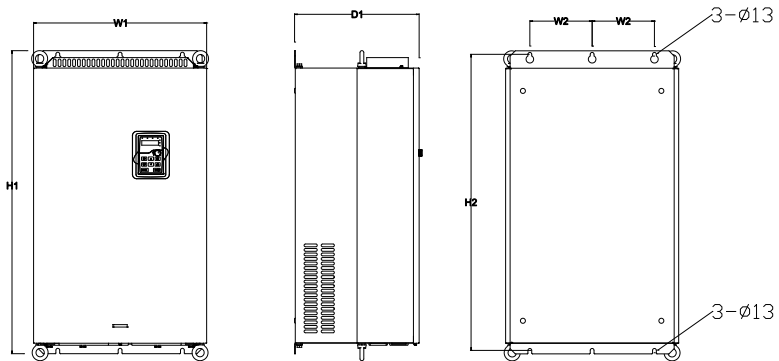

Figure A-14 Wall installation diagram for 660V 160kW–220kW VFD models

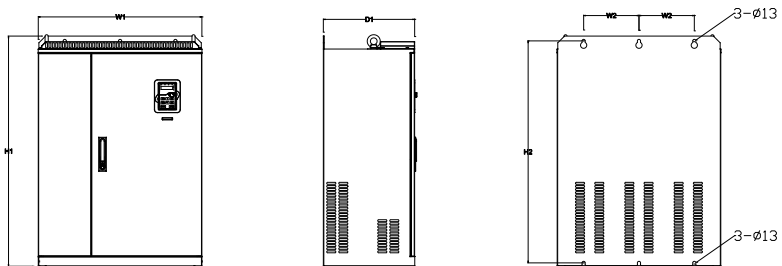

Figure A-15 Wall installation diagram for 660V 250kW–350kW VFD models

Table A-4 Wall installation dimension of 660V 22kW–350kW single VFDs (unit: mm)

Power	W1	W2	W3	H1	H2	D1	D2	Diameter of mounting hole	Screw specification
22 kW -45kW	270	130	—	555	540	325	---	7	M6
55kW–132kW	325	200	—	680	661	365	—	9.5	M8
160kW–220kW	500	180	—	870	850	360	—	11	M10
250kW–350kW	680	230	—	960	926	380	—	13	M12

A.6 Flange installation dimensions of 520V–690V VFDs

For VFDs of AC 3PH 520V (-15%)–690V (+10%)

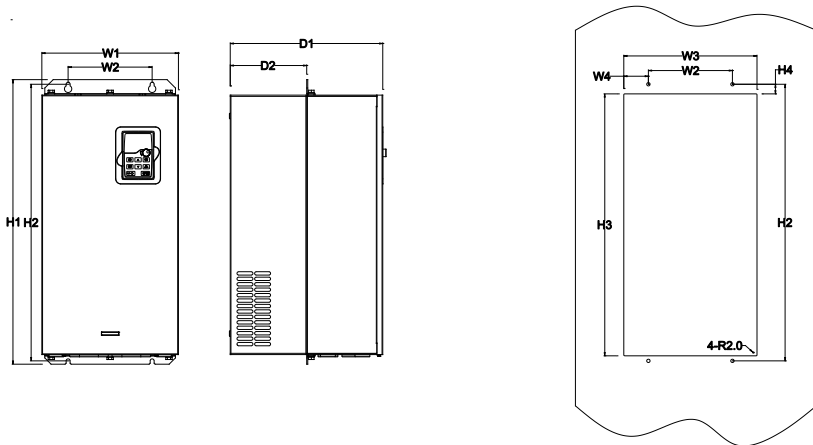

Figure A-16 Flange installation diagram for 660V 22kW–132kW VFD models

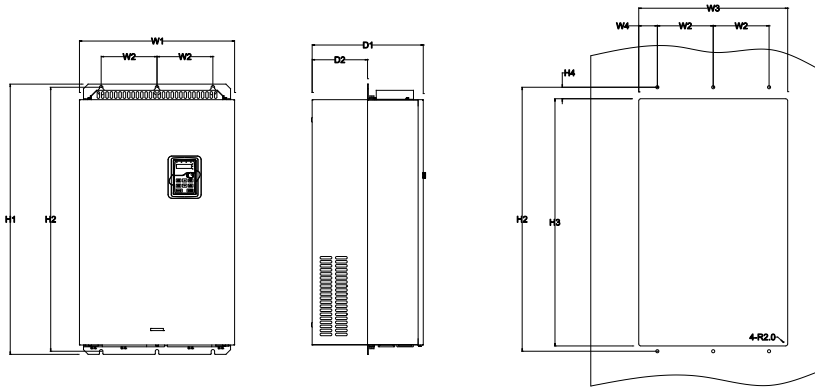

Figure A-17 Flange installation diagram for 660V 160kW-220kW VFD models

Table A-5 Flange installation dimension of 660V 22kW-220kW VFD models (unit: mm)

Power	W1	W2	W3	W4	H1	H2	H3	H4	D1	D2	Diameter of mounting hole	Screw specification
22kW-45kW	270	130	261	65.5	555	540	516	17	325	167	7	M6
55kW-132kW	325	200	317	58.5	680	661	626	23	363	182	9.5	M8
160kW-220kW	500	180	480	60	870	850	796	37	358	178.5	11	M10

A.7 Floor installation dimensions of 520V-690V VFDs

For VFDs of AC 3PH 520V (-15%)-690V (+10%)

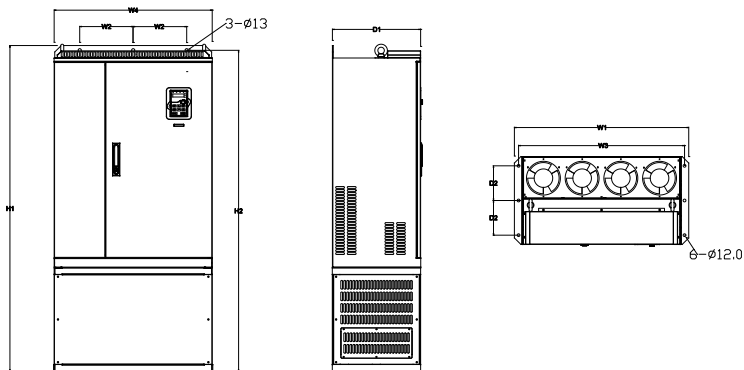

Figure A-18 Floor installation diagram for 660V 250kW-350kW VFD models

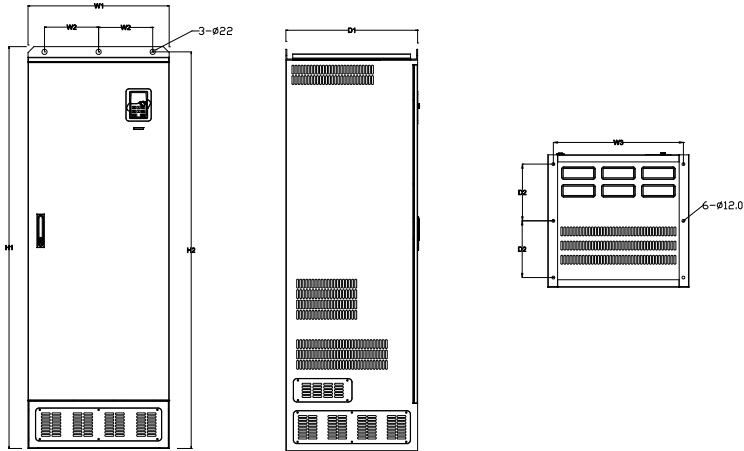

Figure A-19 Floor installation diagram for 660V 400kW–630kW VFD models

Table A-6 Wall installation dimension of 660V 250kW–630kW single VFDs (unit: mm)

Power	W1	W2	W3	W4	H1	H2	D1	D2	Diameter of mounting hole	Screw specification
250kW–350kW	750	230	714	680	1410	1390	380	150	13\12	M10
400kW–630kW	620	230	573	/	1700	1678	560	240	22\12	M10

A.8 Product weight and package dimensions of 380V–440V VFDs

For VFDs of AC 3PH 380V (-15%)–440V (+10%)

Product model	N/W (kg)	G/W (kg)	Package dimension (mm)
GD300-01A-7R5G-4-E	5.6	6.6	428x270x328
GD300-01A-011G-4-E	6.6	8.2	485x325x320
GD300-01A-015G-4-E	8.7	10.3	485x325x320
GD300-01A-018G-4-E	10.4	12.0	485x325x320
GD300-01A-022G-4-E	10.4	12.0	485x325x320
GD300-01A-030G-4-E	16.0	18.5	580x395x360
GD300-01A-037G-4-E	16.0	18.5	580x395x360
GD300-01A-045G-4-E	23.1	27.6	710x450x425
GD300-01A-055G-4-E	23.1	27.6	710x450x425
GD300-01A-075G-4-E	37.0	48.0	710x510x495
GD300-01A-090G-4-E	45.5	56.5	675x470x575
GD300-01A-110G-4-E	46.5	57.5	675x470x575

Product model	N/W (kg)	G/W (kg)	Package dimension (mm)
GD300-01A-132G-4-E	76.0	97.0	971x631x565
GD300-01A-160G-4-E	76.0	97.0	971x631x565
GD300-01A-185G-4-E	76.0	97.0	971x631x565
GD300-01A-200G-4-E	76.0	97.0	971x631x565
GD300-01A-220G-4-E	135	165	1086x826x595
GD300-01A-250G-4-E	135	165	1086x826x595
GD300-01A-280G-4-E	135	165	1086x826x595
GD300-01A-315G-4-E	137	167	1086x826x595
GD300-01A-350G-4-E	137	167	1086x826x595
GD300-01A-400G-4-E	410	450	1850x840x820
GD300-01A-500G-4-E	410	450	1850x840x820

A.9 Product weight and package dimensions of 520V–660V VFDs

For VFDs of AC 3PH 520V (-15%)–660V (+10%)

Product model	N/W (kg)	G/W (kg)	Package dimension (mm)
GD300-01A-022G-6-E	30	33	695x410x470
GD300-01A-030G-6-E	30	33	695x410x470
GD300-01A-037G-6-E	30	33	695x410x470
GD300-01A-045G-6-E	30	33	695x410x470
GD300-01A-055G-6-E	47	58	760x445x580
GD300-01A-075G-6-E	47	58	760x445x580
GD300-01A-090G-6-E	47	58	760x445x580
GD300-01A-110G-6-E	47	58	760x445x580
GD300-01A-132G-6-E	47	58	760x445x580
GD300-01A-160G-6-E	85	112	971x631x565
GD300-01A-185G-6-E	85	112	971x631x565
GD300-01A-200G-6-E	85	112	971x631x565
GD300-01A-220G-6-E	85	112	971x631x565
GD300-01A-250G-6-E	135	165	1086x826x595
GD300-01A-280G-6-E	135	165	1086x826x595
GD300-01A-315G-6-E	137	167	1086x826x595
GD300-01A-350G-6-E	137	167	1086x826x595
GD300-01A-400G-6-E	410	450	1850x840x820
GD300-01A-500G-6-E	410	450	1850x840x820
GD300-01A-630G-6-E	410	450	1850x840x820

Appendix B External optional accessories

B.1 Multi-function expansion card EC-IO304

B.1.1 Brief introduction

Table B-1 Ordering description

Name	Model	Order No.	Remarks
Multi-function expansion card	EC-IO304	11023-00128	Includes three M4*L8.5 hexagonal studs and three M4*8 combination screws with spring and flat washers.

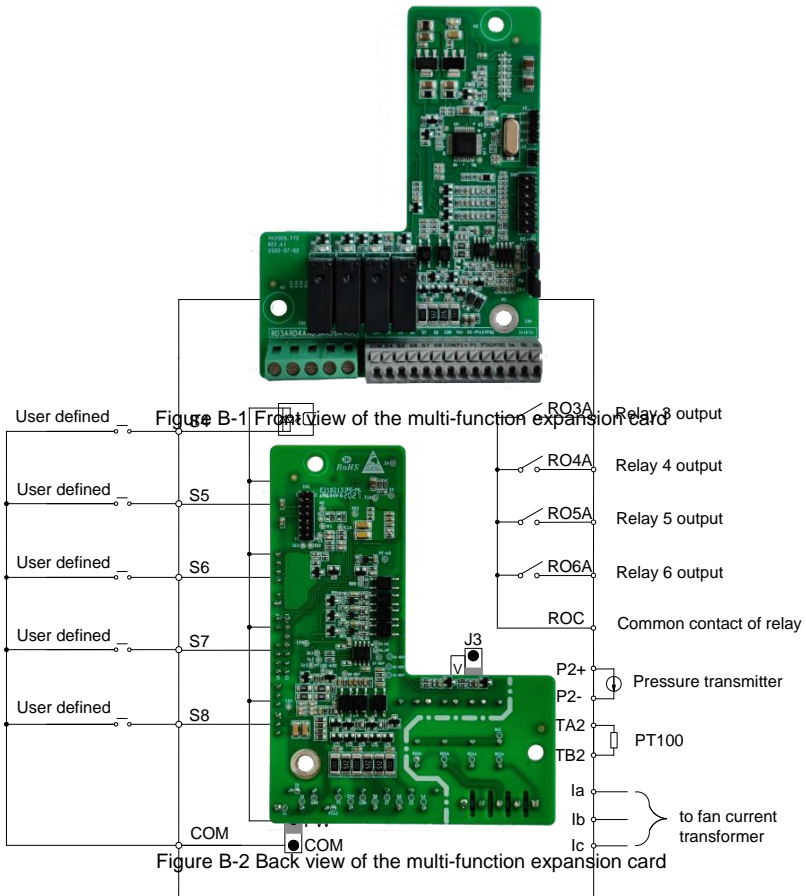

Figure B-3 User terminal wiring diagram of the multi-function expansion card

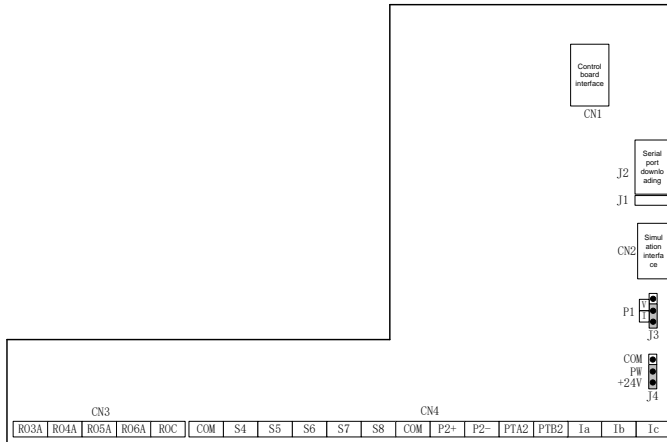

Figure B-4 Terminal layout diagram of the multi-function expansion card

Table B-2 User terminal description of the multi-function expansion card

Category	Terminal	Name	Description
PT100 signal input	PTA2	Analog temperature signal 2	1. Resolution: 1°C 2. Range: -20°C–150°C 3. Detection precision: 3°C
	PTB2		
Pressure signal input	P2+	Analog pressure signal 2	1. Input range: current/voltage is optional, 4–20mA/2–10V corresponds to 0–1.6MPa; of which P1 is switched via J3, and the default is current type. 2. Input impedance: 30kΩ during voltage input; 500Ω during current input 3. Resolution: 5mV (minimum value) 4. Error: ±1%, 25°C
	P2-		
Digital input	S4-COM	Digital input 4	1. Internal impedance: 3.3kΩ 2. 12–30V voltage input is acceptable 3. Max. input frequency: 1kHz You can select internal power (NPN mode) or external power (PNP mode) through J4. The default is internal power (NPN mode).
	S5-COM	Digital input 5	
	S6-COM	Digital input 6	
	S7-COM	Digital input 7	
	S8-COM	Digital input 8	
Relay output	RO3A	NO contact of relay 3	1. Contact capacity: 3A/AC250V, 1A/DC30V 2. Cannot be used as high-frequency switch output.
	RO4A	NO contact of	

Category	Terminal	Name	Description
		relay 4	
	RO5A	NO contact of relay 5	
	RO6A	NO contact of relay 6	
	ROC	Common contact of relay 3–6	
Jumper terminal	J3	P1- analog signal selection terminal	I corresponds to current signal, V corresponds to voltage signal, and the default is current input signal.
	J4	Internal/external power selection terminal	You can select internal power (NPN mode) or external power (PNP mode) through J4. The default is internal power (NPN mode).
Current input	Ia	A phase current input of the fan	1. Range: 0–40A 2. Error: $\pm 3\%$, 25°C 3. Input impedance: 50Ω 4. Recommended transformation ratio of the current transformer: 200 or 1000
	Ib	B phase current input of the fan	
	Ic	C phase current input of the fan	

B.1.2 Assembly instruction

1. Remove the cover and keypad.

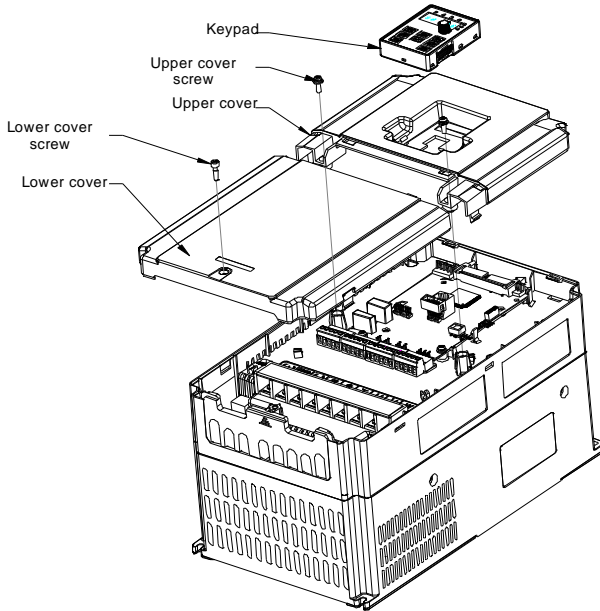

2. Remove one fastening screw (and grounding wires) on the control board.

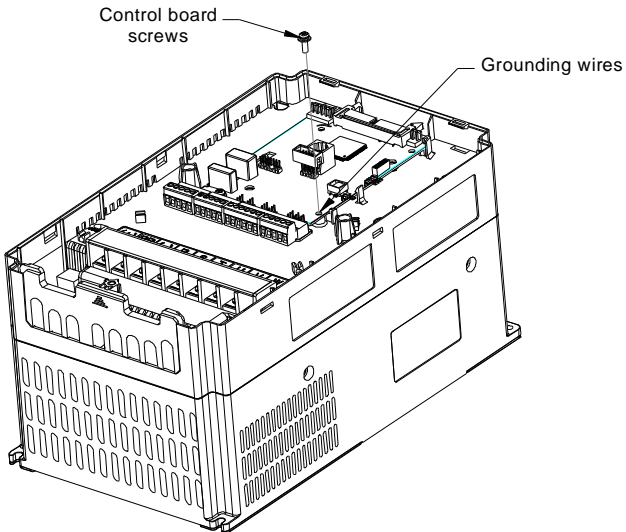

3. Install three hexagonal studs to support the multi-functional expansion card. The installation torque is $12 \pm 10\%$ kgf.cm.

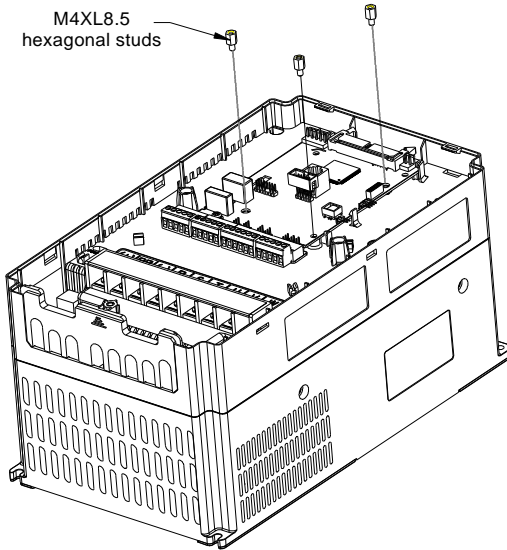

4. Install the multi-functional expansion card (and grounding wires), and use three M4*8 combination screws with spring and flat washers. The installation torque is $10 \pm 10\%$ kgf.cm.

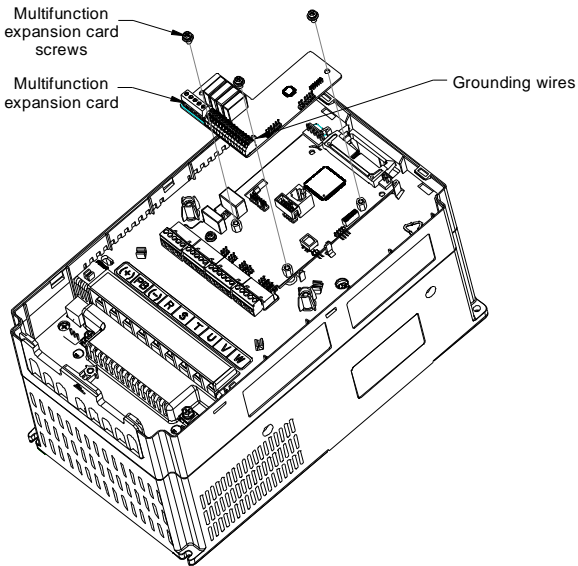

5. Install the cover and keypad after the installation and wiring of the multi-functional expansion card are completed.

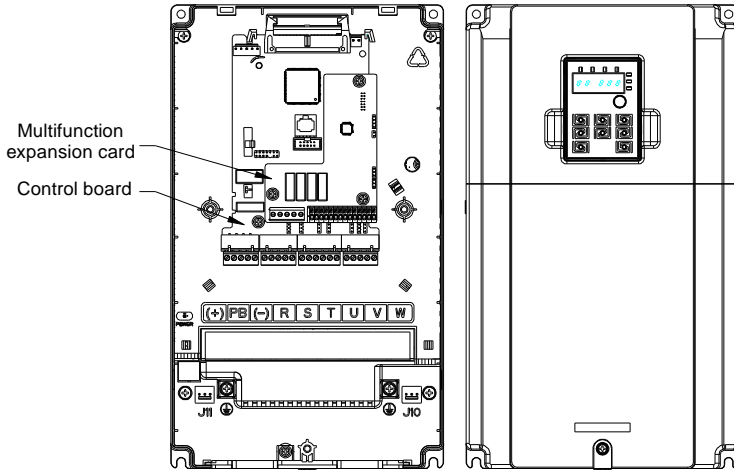

B.2 RS485 communication LCD keypad

B.2.1 LCD keypad introduction

GD300-01A series VFD supports the use of the optional LCD keypad that uses RS485 communication. The LCD keypad can be used to control the start and stop of the VFD, read and write the status data, and set the parameters.

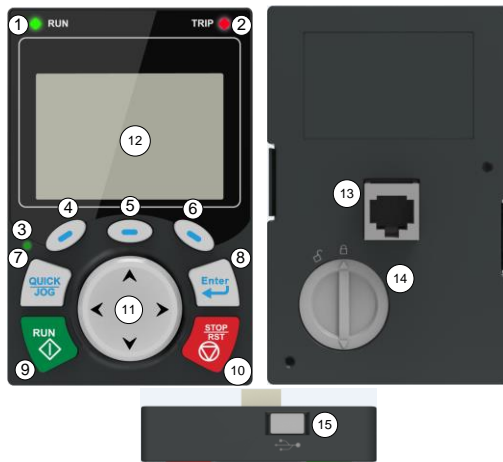

Figure B-5 LCD keypad

Note:







The LCD keypad has a real-time clock for display. After the battery (model: CR2032) is installed, the









clock can work properly even after power failure.

Table B-3 Ordering description for the RS485 communication LCD keypad

Item	Description	Order No.	Remarks
RS485 communication LCD keypad	KEY-LCD01-Z	11022-00141	Includes a 2.5-meter RS485 keypad cable, a 2.5-meter emergency stop cable, a keypad installation bracket, and a CR2032 lithium button battery.

Table B-4 LCD keypad description

Name	Description			
Status indicator	①		VFD running status indicator. LED on: in running state LED off: in stopped state LED blinking: in parameter autotuning state	
	②		Fault indicator. LED on: in fault state LED off: in normal state LED blinking: in pre-alarm state	
	③		Shortcut key indicator, which displays different states under different functions. See the definition of QUICK/JOG for details.	
Keys	④		Function key	The function of a function key varies with the menu and is displayed at the bottom of the display area.
	⑤			
	⑥			
	⑦		Shortcut key	Re-definable. It is defined as JOG function by default, namely jogging. The function of the shortcut key can be set through the ones place of P07.02: 0: No function 1: Jog (linked with indicator ③, logic: steady on) 2: Switch display status using the shifting key 3: Switch between FWD/REV running (linked with indicator ③, logic: steady off) 4: Clear the UP/DOWN setting (linked with

Name	Description		
			indicator ③, logic: steady off) 5: Coast to stop (linked with indicator ③, logic: steady off) 6: Switch running-command giving modes in order (linked with indicator ③, logic: steady off) 7: Quick debugging mode (non factory parameter debugging) Note: After restoring to the default setting, the default function of the shortcut key ⑦ is 1.
	⑧		Confirmation key The confirmation key function varies with the menu (Example: confirming parameter settings, confirming parameter selection, and entering the next menu)
	⑨		Run key Under keypad operation mode, the run key is used for running or autotuning.
	⑩		Stop/ Reset key In running state, you can press this key to stop running or autotuning. This key is restricted by P07.04. In fault alarm state, this key can be used for reset in any control modes.
	⑪		Direction key Up:  Down:  Left:  Right:  Up: Its function varies with the interface (Example: shifting up the displayed/selected item and changing digits) Down: Its function varies with the interface (Example: shifting down the displayed/selected item and changing digits) Left: Its function varies with the interface (Example: switching the monitoring interface) Right: Its function varies with the interface (Example: switching the monitoring interface)
Display area	⑫	LCD	Display screen 240*160 dot-matrix LCD, able to display three monitoring parameters or six sub-menu items simultaneously.
Other	⑬	RJ45 interface	RJ45 interface The RJ45 interface is used to connect to the VFD.

Name		Description		
	⑭	Battery cover	Clock battery cover	To replace or mount the clock battery, remove this cover, and then close the cover after the battery is mounted.
	⑮	USB terminal	Mini USB terminal	The mini USB terminal is used to connect to the USB flash drive through an adapter.

B.2.2 LCD keypad structure

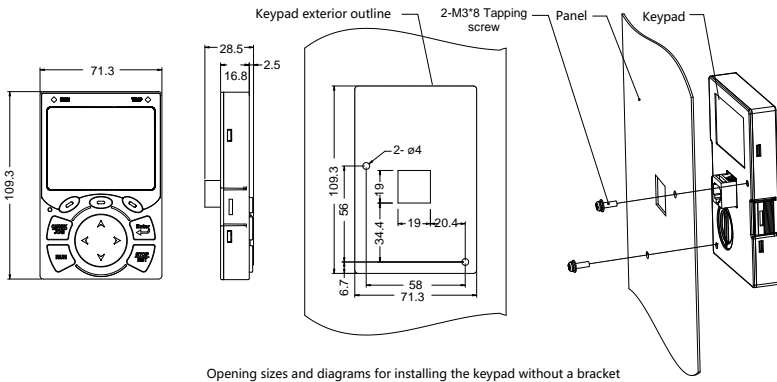

Opening sizes and diagrams for installing the keypad without a bracket

Figure B-6 LCD keypad structure diagram

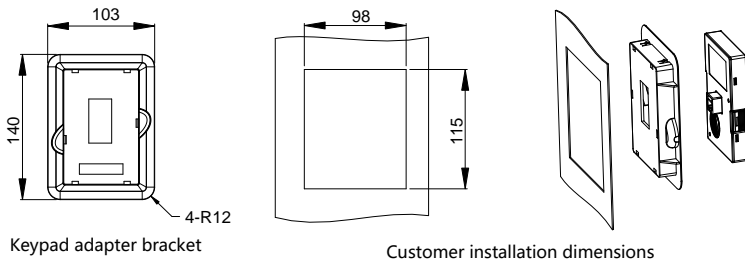

Figure B-7 Keypad installation bracket

B.2.3 RS485 communication cable

B.2.3.1 Connection description

Please use the provided RS485 communication cable, of which one end is connected to the keypad network port and the other is connected to GD300-01A VFD control board user terminal. Do not use the ordinary network cable with both ends of crystal heads.

B.2.3.2 Cable description

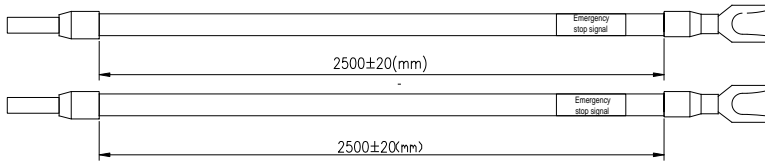

Figure B-8 Emergency stop cable diagram

Note: The emergency stop cable is used for emergency stop control when a device fault occurs and it is often connected to the S1 terminal and COM terminal.

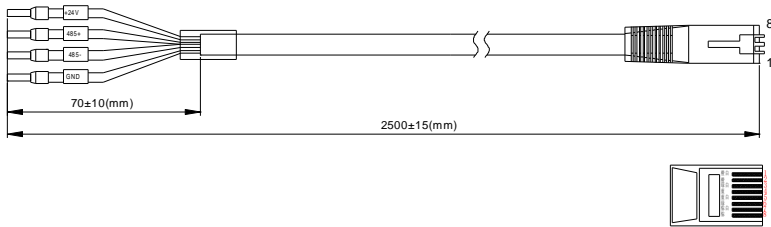

Figure B-9 RS485 communication cable diagram

Table B-5 Wires and terminals

Network port diagram	Terminal	Wire		
	GND	Orange&white	1	Twisted pair
		Orange	2	
	485-	Green&white	3	3 and 6 twisted pair
		Blue	4	
	485+	Blue&white	5	4 and 5 twisted pair
		Green	6	
	+24V	Brown&white	7	Twisted pair
		Brown	8	

B.2.4 Setting parameters on the LCD keypad

B.2.4.1 Initial interface

After power-on and startup, the initial interface appears, as shown in Figure B-10. The LCD keypad displays the product name and software version on this interface and goes to the working environment interface three seconds later.

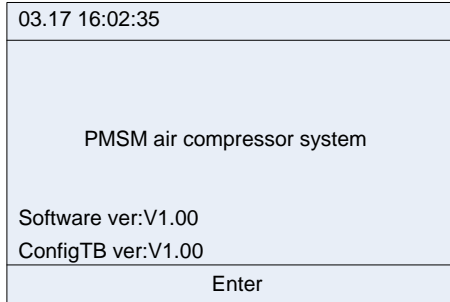

Figure B-10 Initial interface

B.2.4.2 Working environment interface

The working environment interface displays certain parameters about the running.

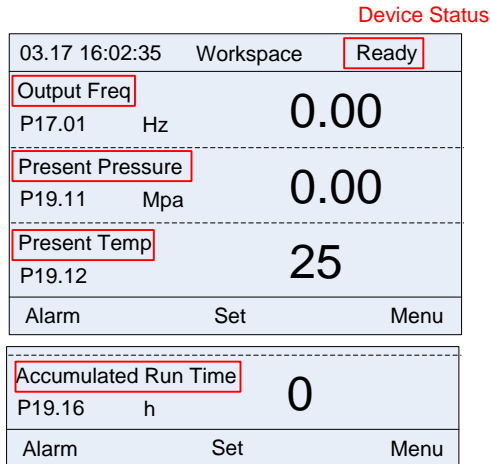

Figure B-11 Working environment

Parameter	Description
Device status	Ready: indicates the device is not started and it does not encounter an alarm. Only when the device is in standby state, the device can be started and the device startup key is valid.
	Run: indicates that the device is started and does not encounter an alarm.
	Fault: indicates that the master VFD or fan VFD encounters a fault. The fault alarm is cleared only after the fault is handled.
	Emergency stop: indicates that the emergency stop key is pressed. It is cleared only after the emergency stop key is reset.

Parameter	Description
	<p>Undervoltage: indicates that the master VFD bus voltage is too low. In this case, you need to check the input power supply.</p> <p>Alarm: The alarm type is displayed in the pre-alarm area.</p> <ul style="list-style-type: none"> ◇ When the temperature reaches the alarm threshold, the alarm is reported and the device stops. ◇ When the temperature reaches the pre-alarm threshold, the temperature is displayed in the pre-alarm area but the device continues running. ◇ When the temperature is lower than the low temperature protection threshold, the alarm is reported, low temperature protection is displayed, and the device stops running. ◇ When the pressure reaches the alarm threshold, the alarm is reported and the device stops. ◇ When the pressure reaches the pre-alarm threshold, the pre-alarm is displayed in the pre-alarm area, but the device continues running. <p>Sleep: When you choose the sleep function and the master empty-load running time reaches the sleep time that is set, the device enters the sleep state. The device automatically wakes up when the pressure is lower than the loading pressure.</p> <p>Stop: indicates that the device has stopped.</p> <p>Restart delay: is used for device protection. If you press the restart key immediately after pressing the stop key, the device can be restarted with a restart delay, which is displayed and counted down. When the countdown time is 0, the device enters the standby state, and the start key is valid.</p> <p>Off: indicates the RS485 communication between the LCD keypad and VFD is disconnected.</p>
Output frequency	It displays the value of the current running frequency of the master VFD.
Present pressure	It displays the value of the current pressure.
Present temperature	It displays the value of the current temperature.
Accumulated run time	It displays the total running time of device.

B.2.4.3 Setting interface

In the main interface, you can press  **Set** to enter the following interface:

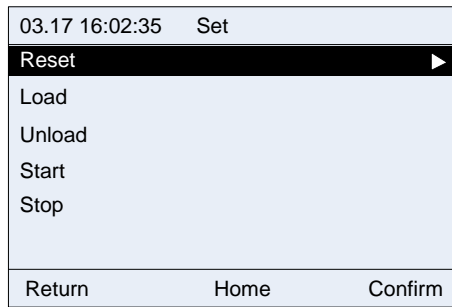





Figure B-12 Setting interface

In this interface, you can press the Up or Down key to select different operation functions. Then press

 **OK** for control; press  **Back** or  **Home** to return to the working environment interface.

- Reset: enables you to reset a fault that the master VFD or fan VFD encounters.
- Load/Unload: controls the start or stop of the intake valve in manual loading or unloading mode.
- Start: enables you to start the device. The device can be started only in standby state.
- Stop: enables you to stop the device.

Note: You can implement the start, stop, and reset functions by pressing the **RUN** and **STOP/RST** keys on the keypad.

B.2.4.4 Alarm interface



You can press  **Alarm** in the main interface to access real-time alarm interface and view all the alarm records since the device power-on.

Note: This function equals the shortcut to **Menu > Fault records > Real-time alarm**. The only difference is that a real-time alarm that is accessed by using this shortcut method cannot be cleared in this interface and it can be cleared only in the fault record interface.

03.17 16:02:35 Real-time alarm	
000. 03-17 16:00:05 xxx fault	
001. 03-17 15:49:30 xxx fault	
002. 03-17 15:08:20 xxx fault	
...	
Return	Home

Figure B-13 Real-time alarm interface

B.2.4.5 Main menu interface

In the main interface, you can press  **Menu** to enter the main menu interface, which contains user parameters, maintenance parameters, protection parameters, running information, master parameters, fan parameters, fault records, VFD information, and system configuration. You can press the **Up** or **Down** key to switch between the menu items and then press  **Select** to enter a specific menu item.

03.17 16:02:35 Menu		
User param ▶		
Maintain param		
Protection param		
Run information		
Master param		
Fan param		
Return	Home	Select
Fault records		
VFD information		
System config ▶		
Return	Home	Select

Figure B-14 Main menu interface

B.2.4.6 User parameter interface

1. Enter the user parameter interface through the main menu.

03.17 16:02:35 User param		
Set pressure	xxx.xx Mpa	▶
Unloading pressure	xxx.xx Mpa	
Loading pressure	xxx.xx Mpa	
Setting Temp	xxxxxx	
Fan Starting Temp	xxxxxx	
Fan Stopping Temp	xxxxxx	
Return	Home	Edit

03.17 16:02:35 User param		
Loading Delay	xxxxxx s	
Stop Delay	xxxxxx s	
No-load Delay	xxxxxx s	
Restart Delay	xxxxxx s	
Sleep Function	Enable	
Load/Unload Mode	Automatic	▶
Return	Home	Edit

03.17 16:02:35 User param		
Restart Delay	xxxxxx s	
Sleep Function	Enable	
Load/Unload Mode	Automatic	
Power consumption	xxxx.x kW.h	
Accumlated Run Time	xxxxxx h	
Timing switch setting		▶
Return	Home	Edit

Figure B-15 User parameter interface

User parameter	Initial value	Function
Set temperature	75°C	Constant exhaust temperature that is set for constant temperature control on fan.
Fan stop temperature	65°C	When the exhaust temperature is lower than this value, the fan is stopped.
Fan startup	75°C	When the exhaust temperature is higher than this value, the

User parameter	Initial value	Function
temperature		fan is started.
Loading delay	10S	After the startup, the air compressor runs with load with this specified delay.
Load/unload mode	Automatic	If the manual mode is used, both load and unload need to be manually performed after the air compressor is started. If the automatic mode is used, the air compressor automatically loads or unloads depending on the pressure after being started.
Sleep function	Enabling	Disable/Enable
No-load delay	300S	Max. continuous empty-load running time allowed by the air compressor. If the time is reached, the air compressor enters the sleep state.
Stop delay	0S	Before stop, the device runs at the empty-load frequency and stops with this specified delay.
Restart delay	30s	After the device stops, the device determines whether to start with this specified delay.
Set pressure	0.70 MPa	Air supply pressure during stable running. The VFD controls the running frequency according to this pressure so as to implement constant pressure for air supply.
Unloading pressure	0.80 MPa	If the pressure is higher than this value when the air compressor is running, the VFD controls the air compressor to run without load.
Loading pressure	0.60 MPa	If the VFD detects the pressure is lower than this value when the air compressor is running without load, the VFD controls the air compressor to run with load. If the VFD detects the pressure is lower than this value when the air compressor is sleeping, the master is waken up.
Power consumption	/	All the electricity consumption (kWh) of the VFD system. The value is automatically generated and cannot be set, but it can be cleared.
Accumulated running time	/	Accumulative running time (hours) of the VFD system. The value is automatically generated and cannot be set, but it can be cleared.
Timing switch setting		Press Set to access the corresponding interface. Startup time: Scheduled time when the device is automatically started. Shutdown time: Scheduled time when the device is automatically stopped.

User parameter	Initial value	Function
		Startup action: Disable/enable (Timed startup is valid only in Enabled state. Otherwise, the device is not automatically started even though the scheduled startup time has been set.) Shutdown action: Disable/enable (Timed stop is valid only in Enabled state. Otherwise, the device is not automatically stopped even though the scheduled shutdown time has been set.)

2. In the user parameter interface, you can edit parameters only after entering the correct user password.

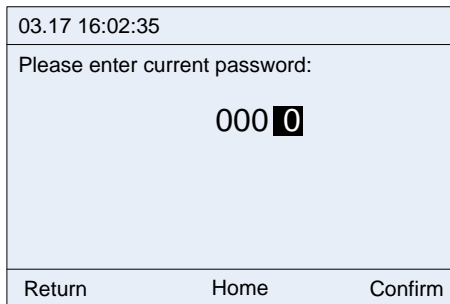

Figure B-16 User password input interface

3. Set user parameters after entering the correct user password.

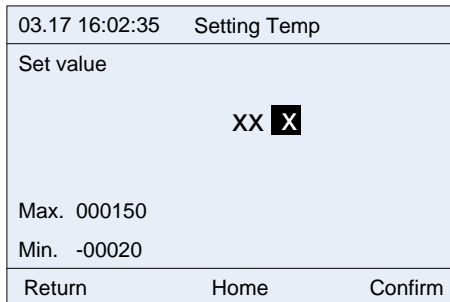

Figure B-17 Temperature setting interface

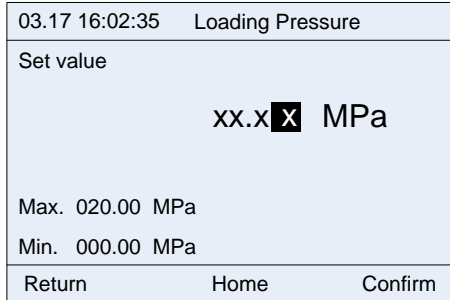

Figure B-18 Loading pressure setting interface

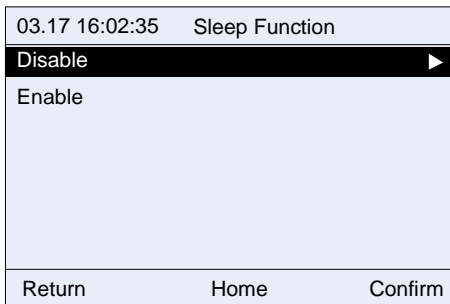

Figure B-19 Sleep function selection interface

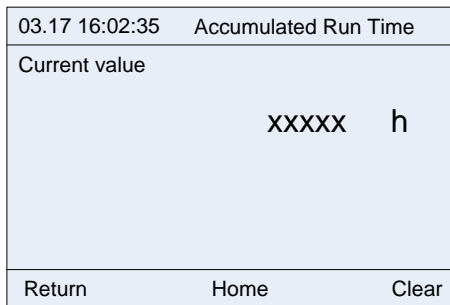

Figure B-20 Accumulative running time display interface

In the **Timing switch setting** (timed startup/stop setting) interface, you can control the VFD to start or stop in different time points each day. To be specific, you can set a maximum of five scheduled startup/stop time points each day from Monday to Sunday.

03.17 16:02:35 Timing switch setting		
Mon. ▶		
Tues.		
Wed.		
Thurs.		
Fri.		
Sat.		
Return	Home	Select

Figure B-21 Date selection interface

03.17 16:02:35 Mon.			
Boot time	ShutTime	Boot	Shutdown ▶
0 0:0 0	0 0:0 0	Disable	Disable
0 0:0 0	0 0:0 0	Disable	Disable
0 0:0 0	0 0:0 0	Disable	Disable
0 0:0 0	0 0:0 0	Disable	Disable
0 0:0 0	0 0:0 0	Disable	Disable
Return	Home	Edit	

Figure B-22 Start/stop action selection interface

03.17 16:02:35 Mon.			
Boot time	ShutTime	Boot	Shutdown
0 0:0 0	0 0:0 0	Disable	Disable
Return	Home	Confirm	

Figure B-23 Start/stop status setting interface

B.2.4.7 Maintenance parameter interface

1. Enter the maintenance parameter interface through the main menu.

03.17 16:02:35 Maintain param		
Air filter set time	xxxxxx h	▶
Oil filter set time	xxxxxx h	
Splitter set time	xxxxxx h	
Lubricat Oil set time	xxxxxx h	
Grease set time	xxxxxx h	
Air filter run time	xxxxxx h	
Return	Home	Edit

03.17 16:02:35 Maintain param		
Grease set time	xxxxxx h	
Air filter run time	xxxxxx h	
Oil filter run time	xxxxxx h	
Splitter run time	xxxxxx h	
Lubricat Oil run time	xxxxxx h	
Grease run time	xxxxxx h	▶
Return	Home	Edit

Figure B-24 Maintenance parameter interface

Maintenance parameter	Initial value	Function
Air filter set time	0	If the accumulative air filter use time exceeds this value, a pre-alarm is displayed. If this value is set to 0, no pre-alarm is displayed.
Oil filter set time	0	If the accumulative oil filter use time exceeds this value, a pre-alarm is displayed. If this value is set to 0, no pre-alarm is displayed.
Splitter set time	0	If the accumulative splitter use time exceeds this value, a pre-alarm is displayed. If this value is set to 0, no pre-alarm is displayed.
Lubricate oil set time	0	If the accumulative lubrication oil use time exceeds this value, a pre-alarm is displayed. If this value is set to 0, no pre-alarm is displayed.
Grease set time	0	If the accumulative grease use time exceeds this value, a pre-alarm is displayed. If this value is set to 0, no pre-alarm is displayed.
Air filter run time	/	It is cleared when a new air filter is used.

Maintenance parameter	Initial value	Function
Oil filter run time	/	It is cleared when a new oil filter is used.
Splitter run time	/	It is cleared when a new splitter is used.
Lubricate oil run time	/	It is cleared when new lubrication oil is used.
Grease run time	/	It is cleared when new grease is used.

2. You can edit parameters after entering the correct administrator password.

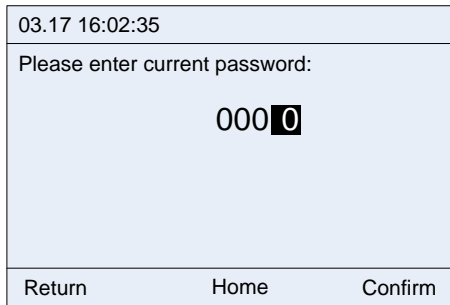

Figure B-25 Administrator password input interface

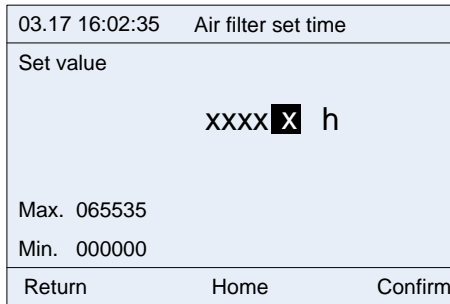

Figure B-26 Air filter set time

Maintenance parameters are set according to the use status of accessories. During running, if the use time of an accessory is equal to or greater than the set time, a pre-alarm is displayed, indicating that the accessory needs maintenance or it needs to be replaced. The use time needs to be cleared to 0 when the new accessory is used.

03.17 16:02:35 Oil filter run time		
Current value		
xxxxxx h		
Return	Home	Clear

Figure B-27 Accumulative oil filter use time

B.2.4.8 Protection parameter interface

1. Enter the protection parameter interface through the main menu.

03.17 16:02:35 Protection param		
Prealarm Pressure	xxx.xx MPa	▶
Alarm Pressure	xxx.xx Mpa	
Prealarm Temp	xxxxxx	
Alarm Temp	xxxxxx	
Low Temp Protect Thred	xxxxxx	
Auxiliary Press Protection	Invalid	
Return	Home	Edit

03.17 16:02:35 Protection param		
Auxiliary Press Prealarm	xxx.xx MPa	
Auxiliary Press Alarm	xxx.xx MPa	
Auxiliary Temp Proteciton	Invalid	
Present Auxiliary Temp	xxxxxx	
Auxiliary Temp Prealarm	xxxxxx	
Auxiliary Temp Alarm	xxxxxx	▶
Return	Home	Edit

Figure B-28 Protection parameter interface

Protection parameter	Initial value	Function
Prealarm temperature	105°C	When the actual exhaust temperature is higher than this temperature, a pre-alarm is reported.
Alarm temperature	110°C	When the actual exhaust temperature is higher than this temperature, an alarm is reported, and the device is stopped.

Protection parameter	Initial value	Function
Prealarm pressure	0.90Mpa	When the actual air supply pressure is higher than this pressure, a pre-alarm is reported.
Alarm pressure	1.00Mpa	When the actual air supply pressure is higher than this pressure, an alarm is reported, and the device is stopped.
Auxiliary temperature prealarm	105°C	When the detected temperature is higher than this temperature, a pre-alarm is reported. This parameter is valid only after it is enabled in system configuration.
Auxiliary temperature alarm	110°C	When the detected temperature is higher than this temperature, an alarm is reported, and the device is stopped. This parameter is valid only after it is enabled in system configuration.
Auxiliary pressure prealarm	0.90Mpa	When the detected pressure is higher than this pressure, a pre-alarm is reported. This parameter is valid only after it is enabled in system configuration.
Auxiliary pressure alarm	1.00Mpa	When the detected pressure is higher than this pressure, an alarm is reported. This parameter is valid only after it is enabled in system configuration.
Low temperature protection threshold	-10°C	When the detected temperature is lower than this temperature, a low temperature pre-alarm is reported. This parameter is valid only after it is enabled in system configuration.
Current auxiliary temperature	/	It displays the auxiliary temperature that is currently detected.
Current auxiliary pressure	/	It displays the auxiliary pressure that is currently detected.
Enable auxiliary temperature protection	Disable	Disable/Enable
Enable auxiliary pressure protection	Disable	Disable/Enable

2. You can edit parameters only after entering the correct administrator password.

03.17 16:02:35		
Please enter current password:		
000 <input type="password" value="0"/>		
Return	Home	Confirm

Figure B-29 Administrator password input interface

03.17 16:02:35	Alarm Pressure	
Set value		
xx.x <input type="password" value="x"/> MPa		
Max. 020.00 MPa		
Min. 000.00 MPa		
Return	Home	Confirm

Figure B-30 Alarm pressure parameter setting interface

03.17 16:02:35	Auxiliary Temp Protection	
Invalid <input type="checkbox"/>		
Valid <input type="checkbox"/>		
Return	Home	Confirm

Figure B-31 Auxiliary temperature protection enabling

B.2.4.9 Running information

1. Enter the running information interface through the main menu. Running information includes master running information and fan running information.

03.17 16:02:35 Run information		
Master ▶		
Fan		
Return	Home	Select

Figure B-32 Running information interface

03.17 16:02:35 Master running info		
Output Current	xxxx.x A	▶
Output Voltage	xxxxxx V	
Motor Speed	xxxxxx rpm	
Output Freq	xxx.xx Hz	
Motor Actual Output Power	xxxx.x kW	
Present Pressure	xxx.xx MPa	
Return	Home	

Figure B-33 Master running information

03.17 16:02:35 Fan running info		
Fan State	Stop	▶
Temperature	xxxxxx	
Fan Phase A Display Current	xxxx.x A	
Fan Phase B Display Current	xxxx.x A	
Fan Phase C Display Current	xxxx.x A	
Return	Home	

Figure B-34 Fan running information

Note: Master and fan running information is read only and therefore cannot be edited.

B.2.4.10 Master parameter interface

1. Enter the master parameter interface through the main menu.

03.17 16:02:35 Master Param		
Max Ouput Freq	xxx.xx Hz	▶
Run Freq Up limit	xxx.xx Hz	
Run Freq Down limit	xxx.xx Hz	
Load Run Low Limit Freq	xxx.xx Hz	
No-load Run Freq	xxx.xx Hz	
Acc time	xxxx.x s	
Return	Home	Edit

03.17 16:02:35 Master param		
Sample Cycle	xx.xxx s	
Prop Gain	xxx.xx	
Integral Time	xxx.xx s	
Differential Time	xxx.xx s	
PID Output Uplimit	xxxx.x %	
PID Output Downlimit	xxxx.x %	▶
Return	Home	Edit

Figure B-35 Master parameter interface

Master parameter	Initial value	Function
Proportional gain (Kp)	10.00	It indicates the speed of tracking the set working pressure. A greater value indicates a higher speed of tracking and easier oscillation. A smaller value indicates a lower speed of tracking and slower adjustment. The recommended setting range is 5.00–15.00.
Integral time	2.00	The recommended setting range is 2.00–4.00.
Differential time (Td)	1.00	It is used for lag tracking on the large-scale lag system (such as temperature).
Sampling time (T)	0.100s	It indicates the sampling period for feedback values.
PID output upper limit	100%	It indicates the upper limit of the output of the PID regulator.
PID output lower limit	0.0%	It indicates the lower limit of the output of the PID regulator. It is set based on the lower limit frequency.
Max. output frequency	50.00Hz	It indicates the maximum output frequency of the VFD.

Master parameter	Initial value	Function
Upper limit of running frequency	50.00Hz	It indicates the upper limit of the output frequency of the VFD.
Lower limit of running frequency	00.00Hz	It indicates the lower limit of the output frequency of the VFD.
Loaded running frequency lower limit	40.00Hz	It indicates the minimum working frequency that is allowed to output when the pressure exceeds the set value but does not reach the unloading pressure during regulation.
Empty-load running frequency	38.00Hz	It indicates the working frequency when the air compressor is empty loaded.
ACC time	Model depended	It indicates the time taken by the VFD to accelerate from 0Hz to the maximum frequency.
DEC time	Model depended	It indicates the time taken by the VFD to decelerate from the maximum frequency to 0Hz.

2. You can edit parameters only after entering a correct administrator password.

03.17 16:02:35

Please enter current password:

000

Return
Home
Confirm

Figure B-36 Administrator password input interface

03.17 16:02:35 Max Output Freq

Set value

xxx.x Hz

Max. 600.00 MPa

Min. 000.00 MPa

Return
Home
Confirm

Figure B-37 Maximum output frequency setting interface

03.17 16:02:35	Differential time	
Set value		
XX.X X S		
Max. 010.00 s		
Min. 000.00 s		
Return	Home	Confirm

Figure B-38 Figure B-38 Differential time setting interface

B.2.4.11 Fan parameter interface

1. Enter the fan parameter interface through the main menu.

03.17 16:02:35	Fan param	
Rated Fan Current	xxxx.x A	▶
Fan Current Transfor Ratio xxx.x		
Current Imbalance Coeffi xxx.xx		
Phase A Cur Calib Coeffi xxxx.x %		
Phase B Cur Calib Coeffi xxxx.x %		
Phase C Cur Calib Coeffi xxxx.x %		
Return	Home	Edit

Figure B-39 Figure B-39 Fan parameter interface

Fan parameter	Initial value	Function
Rated fan current	0.0A	It is associated with the power-frequency fan current detection and overload protection functions. It is valid only when the value is not 0, and it is invalid when the value is 0. Setting range: 0–40.0
Fan current transfer ratio	1000.0	Setting range: 1.0–4000.0
Current imbalance coefficient	1.60	When ratio of the maximum current to the minimum current among the fan three-phase currents is greater than this value, the VFD reports the fan current unbalance fault. Setting range: 1.00–3.00
Phase A current calibration coefficient	100.0%	Actual current = Displayed current * Current coefficient factor

Fan parameter	Initial value	Function
Phase B current calibration coefficient		Setting range: 0.0–150.0% Note: When parameters are restored to the factory settings, this value is remained.
Phase C current calibration coefficient		

2. You can edit parameters only after entering a correct administrator password.

03.17 16:02:35		
Please enter current password:		
000 <input type="password"/>		
Return	Home	Confirm

Figure B-40 Administrator password input interface

03.17 16:02:35		Rated Fan Current
Set value		
XX. <input type="text"/> A		
Max. 0040.0 A		
Min. 0000.0 A		
Return	Home	Confirm

Figure B-41 Fan rated current setting interface

03.17 16:02:35		Phase A Cur Calib Coeffi
Set value		
XXX. <input type="text"/> %		
Max. 0150.0 %		
Min. 0000.0 %		
Return	Home	Confirm

Figure B-42 Fan A-phase current correction factor setting interface

B.2.5 Fault records

The fault record interface is used to display the fault and alarm information about current device running. If an alarm is reported, alarm information is displayed. Fault records include VFD faults, air compressor faults, real-time alarms, and historic alarms.

03.17 16:02:35 Fault records		
VFD fault ▶		
AirCompressor fault		
Real-time alarm		
Historical alarm		
Return	Home	Select

Figure B-43 Fault record interface

B.2.5.1 VFD fault interface

This interface displays fault information about the VFD. You can view the current fault and last five faults.

03.17 16:02:35 VFD fault		
Type of Current Fault	000019	▶
Type of Last Fault	0000xx	
Type of 2 nd Last Fault	0000xx	
Type of 3 rd Last Fault	0000xx	
Type of 4 th Last Fault	0000xx	
Type of 5 th Last Fault	0000xx	
Return	Home	Select

03.17 16:02:35 VFD fault		
Type of Current Fault:		
Current detection fault(ItE)		
Return	Home	

Figure B-44 VFD fault interface

B.2.5.2 Air compressor fault interface

This interface displays air compressor exception information, including the air filter, oil filter, and separator blockage, maintenance need, and auxiliary pressure or temperature pre-alarm or alarm.

03.17 16:02:35	Air Compressor fault
000.	Oil filter jam signal fault
001.	External Signal 1 fault
002.	Pressure Prealarm
003.	Pressure Signal fault
004.	Maintenance timeout
...	
Return	Home

Figure B-45 Air compressor fault interface

B.2.5.3 Real-time alarm interface

This interface displays all fault records including fault time in real time since the keypad is started. If the keypad is re-powered on, the real-time alarm records are cleared but these records have been saved in the history alarm records before the power-off.

When there are many real-time alarm records, you can use the Up and Down keys to shift.

In the working environment interface, the  **Alarm** key is the shortcut access to real-time alarms, but alarm information can be cleared only in this interface.

03.17 16:02:35	Real-time alarm	
000.	03-17 16:00:05 xxx fault	
001.	03-17 15:49:30 xxx fault	
002.	03-17 15:08:20 xxx fault	
...		
Return	Home	Clear

Figure B-46 Real-time alarm interface

When you need to clear real-time alarm records, you can press  **Clear** and enter a correct user password to clear the records.

03.17 16:02:35		
Please enter current password:		
000 <input type="password" value="0"/>		
Return	Home	Confirm

03.17 16:02:35		
Confirm to clear the realtime alarm info?		
Return	Home	Confirm

Figure B-47 Alarm record clearing interface

Note: The real-time alarm interface can keep a maximum of 50 fault records due to the restriction of memory. When the number of fault records exceed 50, if you do not manually clear these extra records, the earliest fault records will be automatically overwritten.

B.2.5.4 Historic alarm interface

The fault information in the historic alarm interface is the same as that in the real-time alarm interface. The only difference is that the historic alarm interface always keeps the fault records even if the keypad is powered off, while the real-time alarm interface clears all the fault records if the keypad is powered off.

Note: The historic alarm interface can keep a maximum of 500 fault records due to the restriction of memory. When the number of fault records exceed 500, if you do not manually clear these extra records, the earliest fault records will be automatically overwritten.

B.2.6 VFD information

Enter the VFD information interface through the main menu, as shown in the following figure.

03.17 16:02:35 VFD information		
Master ▶		
Fan		
Return	Home	Select

Figure B-48 VFD information interface

03.17 16:02:35 Master VFD info		
Ctrl Board Software Ver xxx.xx ▶		
Present Temperature	xxxx.x	
Digital Input Terminal State	xxxxxx	
Digital Output Terminal State	xxxxxx	
Analog P1	xxx.xx V	
Analog PT1	xxx.xx V	
Return	Home	
Analog P2	xxx.xx V	
Analog PT2	xxx.xx V	
Air Compressor Ctrl Mode Invalid ▶		
Return	Home	

Figure B-49 Master VFD information

Note: VFD information is read only.

B.2.7 System configuration

Enter a correct factory password to enter the system configuration interface.

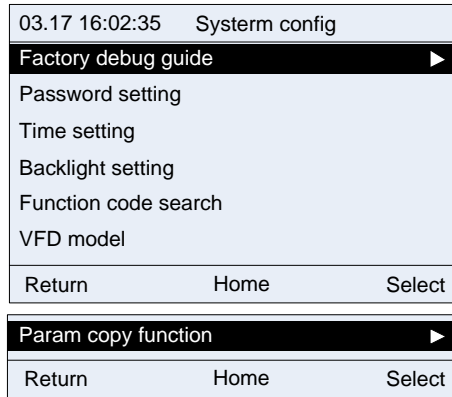

Figure B-50 System configuration interface

B.2.7.1 Factory commissioning wizard

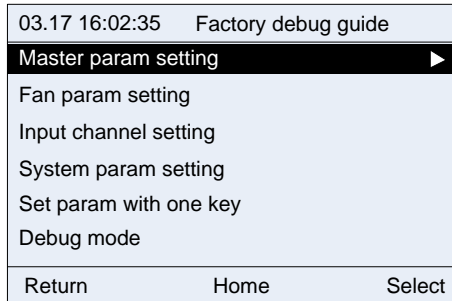

Figure B-51 Factory commissioning wizard interface

Factory commissioning procedure

Step 1 Enter the master parameter setting interface.

Set motor parameters according to the motor nameplate. Perform motor parameter identifying. Enter motor parameters for motor variable-frequency commissioning. Parameter autotuning is located at the last line in the master parameter setting interface, as shown in Figure B-52.

03.17 16:02:35 Master param setting		
Motor type	AM	▶
Max frequency	050.00 Mpa	
Rated power	0090.0 kW	
Rated frequency	050.00 Hz	
Rated voltage	000380 V	
Rated current	0176.0 A	
Return	Home	Edit

03.17 16:02:35 Master param setting		
Stator resistor	00.030 Ω	
Rotor resistor	00.025 Ω	
Leakage inductance	00.006 mH	
Mutual inductance	00.169 mH	
No-load current	0040.8 A	
Param auto-tuning		▶
Return	Home	Edit

Figure B-52 Master parameter setting interface

Step 2 Enter the system parameter setting interface.

According to the sensor configuration, set the pressure sensor parameters, temperature sensor parameters, and oriented function parameters. Then return to the system configuration interface.

03.17 16:02:35 System param setting		
Max voltage limit	xxxx.x %	▶
Uplimit freq press drop	xxx.xx MPa	
Temp sensor channel	PT1	
Power correct coeffi	xxxxxx %	
Uplimit freq drop rate	xxx.xx Hz	
Press sensor P1 uplimit	xxx.xx MPa	
Return	Home	Edit

Maintain Timeout	xxxxxx h	
Press sensor channel	P1	
Press sensor P2 Uplimit	xxx.xx MPa	▶
Return	Home	Edit

Figure B-53 System parameter setting interface

Step 3 Press the **Set up Parameters** key to automatically set parameters.

Step 4 Enter the commissioning mode. Run the master and fan in jogging mode to check the motor rotation direction.

Step 5 Adjust user parameters, factory parameters, and maintenance parameters according to the manual.

During commissioning, if a signal exception occurs, check VFD information to view the signal status and handle the exception.

B.2.7.2 Date and time display

Generally, the date and time in the format of *AA.BB aa:bb:cc* is displayed in the upper left corner of the keypad interface. In the format, *AA* indicates month, *BB* indicates date, *aa* indicates hour, *bb* indicates minute, and *cc* indicates second. For example, "03.17 16:02:35" in the following figure indicates the current time is 16:02:35 on March 17.

Note: The real-time clock function can be used properly only when batteries are available. The battery compartment is located on the back of the keypad. You only need to remove the lid to check whether batteries are available.

03.17 16:02:35	Workspace	Ready
Output Freq P17.01 Hz	0.00	
Present Pressure P19.11 Mpa	0.00	
Present Temp P19.12 °C	25	
Alarm	Set	Menu

B.2.7.3 Password setting

The controller provides multi-level password and permission management. The mapping between passwords and permissions is as follows:

- User password: able to modify user password and clear fault records.
- Administrator password: able to modify maintenance parameters, protection parameters, master parameters, and fan parameters, in addition to the permissions with a user password.
- Factory password: able to modify all parameters.
- Super factory password: able to modify all parameters.

Passwords are changeable. To change a password, enter the password correctly, enter a new password, and then re-enter the new password for confirmation. The password can be changed successfully only when no errors are made.

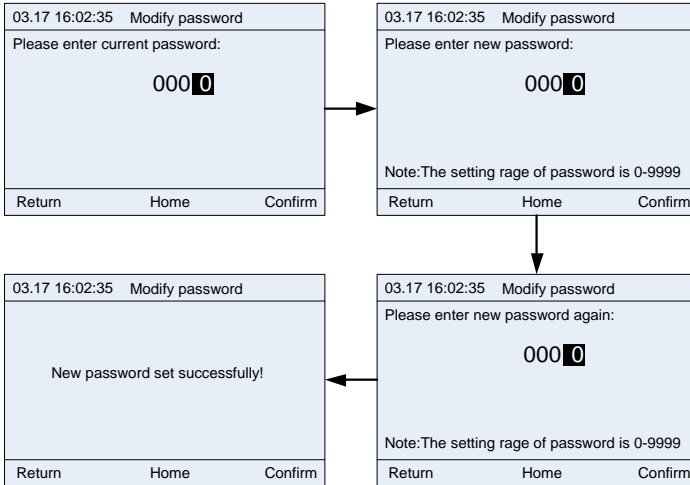

Figure B-54 Password changing interface

B.2.7.4 Date and time setting

If the keypad time is incorrect, you can change the time in the date and time setting interface. The year setting range is 2000–2099.

You can move the black cursor leftward or rightward through the keypad, adjust the digits through the

Up or Down key, and then press  to confirm the change.

Note: Ensure that batteries have been installed in the back of the keypad.

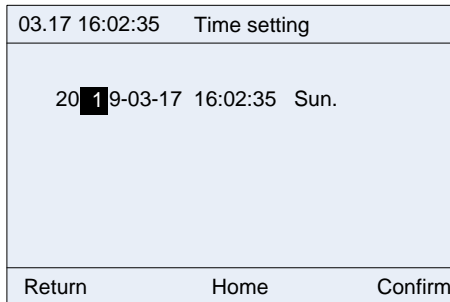

Figure B-55 Date and time setting interface

B.2.7.5 Screen backlight setting

The LCD keypad backlight setting includes the backlight brightness and time.

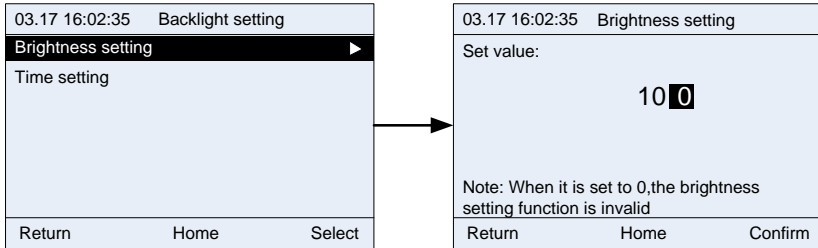

Figure B-56 Screen backlight brightness setting interface

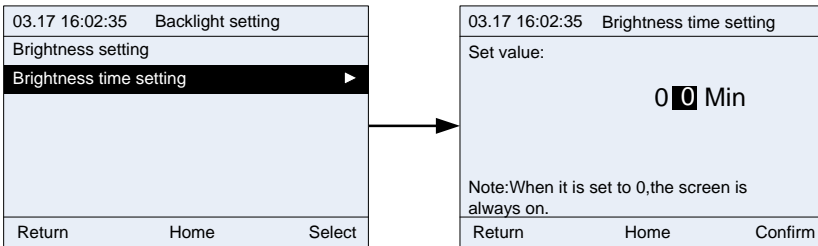

Figure B-57 Screen backlight time setting interface

B.2.7.6 Function code searching

The function code searching interface allows you to query and modify all VFD function codes. Figure B-58 shows an example of how to query and modify P00.04.

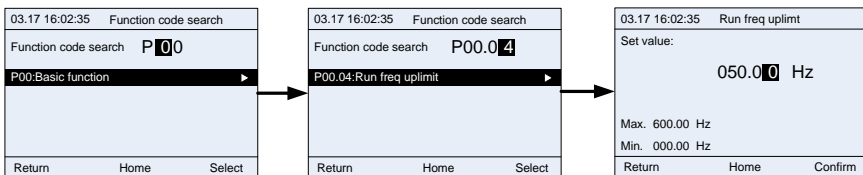

Figure B-58 Function code searching interface

B.2.7.7 VFD model selection

This interface allows you to select the VFD model. Different VFD models may be different in the function codes.

When communication is proper, the keypad automatically identifies the VFD model. In certain cases, you need to manually select the VFD model.

For example, when the connected VFD is Goodrive300-21, and the dual-VFD integrated machine contains the master and fan, the keypad identifies Goodrive300-21 (master) by default. In this case, if you want to check the function codes of the fan VFD, you need to manually switch to the fan VFD.

Note: After you search fan VFD function codes and return to the main menu interface, the keypad will automatically identify the master VFD again.

Figure B-59 lists the supported VFD series. In future, more VFD series may be supported.

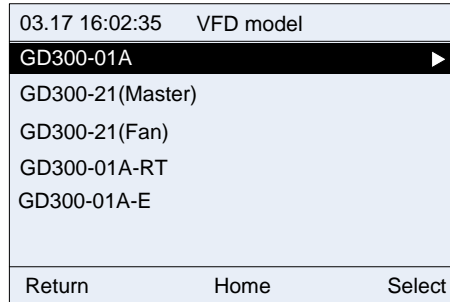

Figure B-59 VFD model selection interface

B.2.7.8 Parameter copying

The parameter copying function allows you to upload parameters from the connected VFD to the keypad and also allows you to download parameters from the keypad to the connected VFD.

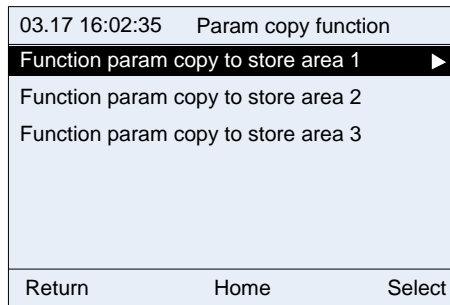



Figure B-60 Parameter copying function 1

Each storage area supports parameter upload, parameter download 1 (all parameters), parameter download 2 (non motor parameters), and parameter download 3 (only motor parameters). After you

press  for confirmation, the corresponding operation is performed.

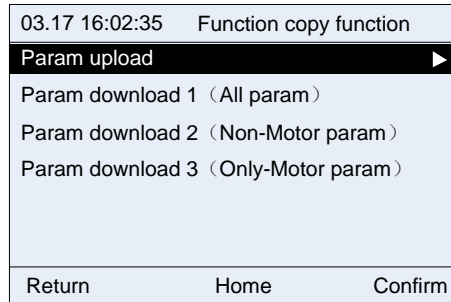
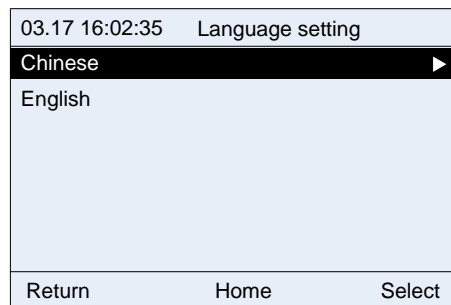

Figure B-61 Parameter copying function 2

B.2.7.9 Language setting

The 485 LCD keypad supports switching between Chinese and English. Each time you switch between Chinese and English, the switching will take effect only after the keypad is powered off and restarted.



B.3 HMI touch screen

B.3.1 Specifications

Table B-6 Touch screen specifications

Category	Function	Specifications
Hardware parameter	Screen	7" 16: 9 TFT LCD screen
	Resolution	800x480
	Color	24 bits
	Brightness	360 cd/m ²
	Backlight	LED
	LCD lifetime	50000 hours
	Touch screen	4-wire industrial resistance touch screen
	CPU	600MHz ARM Cortex-A8
	Memory	128M Flash + 128M DDR3
RTC	Real-time clock (embedded)	



Category	Function	Specifications
	Ethernet	None
	USB port	1 USB Slave 2.0 port; 1 USB Host 2.0 port
	Program download method	USB Slave/U disk
	Serial communication port	COM1: RS232/RS485/RS422 COM2: RS485 COM3: RS232
	Viewing angle of LCD (T/B/L/R)	50°/70°/70°/70°
Electrical performance	Rated power	< 10W
	Rated voltage	DC24V, allowable working range DC 9V–28V
	Power supply protection	Surge protection capability
	Allowed power outage	< 5ms
	CE & RoHS	Compliant with EN61000-6-2:2005 and EN61000-6-4:2007 Compliant with RoHS lightning surge ±1kV, group pulse ±2kV Static contact 4kV, air discharge 8kV
Environment requirement	Working temperature	0–50°C
	Storage temperature	-20–60°C
	UV resistance	Disallowed to work under strong UV (such as direct sunlight)
	Ambient humidity	10–90%RH (no condensation)
	Shock resistance	10–25Hz (X, Y, Z direction 2G/30 minutes)
	Cooling method	Natural air cooling
Mechanical performance	Ingress protection rating	The front panel reaches IP65 (installed with a flat panel cabinet), and the rear shell of the device reaches IP20.
	Mechanical structure	Engineering plastic
	Cut-out dimensions	192mm×138mm
	Overall dimensions	204mm×145mm×33.8mm
	Overall weight	About 560g

Table B-7 Ordering description for the touch screen

Item	Description	Order No.
HMI touch screen	Includes a 3-meter RS485 communication cable and a 3-meter 24V power supply cable.	11026-00011

B.3.2 Connection terminals

Power supply terminals (Pins 1–3, from left to right)		
	Pin1	FG
	Pin2	0V
	Pin3	DC24V
DB9 serial port terminals		
	Pin1	Rx-(B)
	Pin2	RxD (COM1 RS232)
	Pin3	TxD (COM1 RS232)
	Pin4	Tx-
	Pin5	GND
	Pin6	Rx+(A)
	Pin7	RxD (COM3 RS232)
	Pin8	TxD (COM3 RS232)
	Pin9	Tx+
RS485 terminals (Pins 1–2, from left to right)		
	Pin1	A+ (COM2 RS485)
	Pin2	B- (COM2 RS485)
USB Host		

	USB Type A	Used to connect external peripherals such as the USB disk and barcode scanning device
USB Slave		
	MicroUSB	Used for program download and debugging

B.3.3 Wiring description

In order to drive and manage the air compressor better, use the provided RS485 communication cable, of which one end is connected to the touch screen power supply port and DB9 serial port and the other is connected to GD300-01A VFD control board terminal.

B.3.4 Cable description

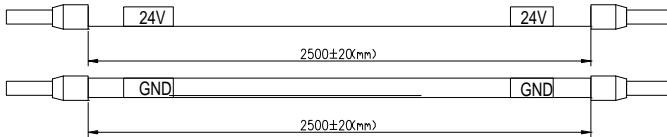

Figure B-62 Touch screen 24V power supply cable diagram

Note: As shown in Figure B-62, the touch screen power supply interface is connected to CN4 of GD300-01A VFD control board.

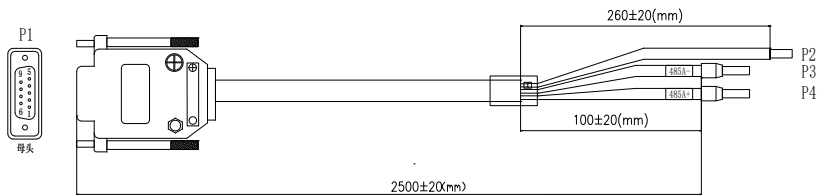
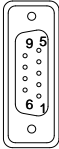

Figure B-63 Touch screen RS485 communication cable diagram

Terminal diagram	Terminal		Cable	
 <p>P1 Female</p>	P1(1PIN)	RX-(B)	P3	485-
	P1(6PIN)	RX+(A)	P4	485+
	Iron shell		P2	Shield layer grounding cable

B.3.5 Installation dimensions and description

B.3.5.1 Touch screen installation dimensions

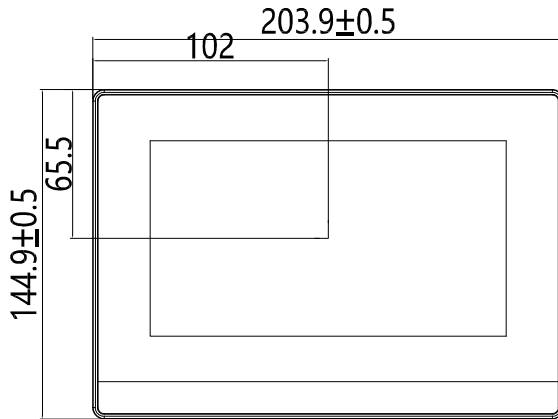
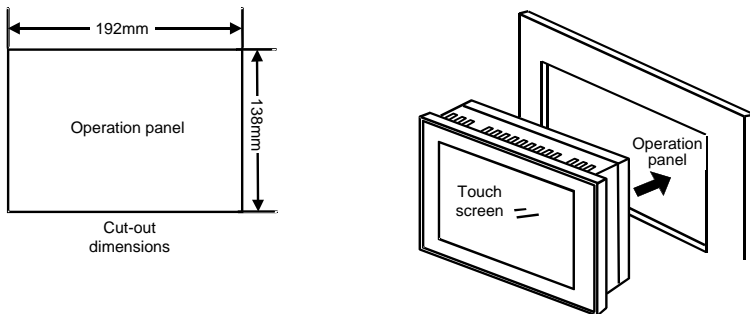

Figure B-64 Touch screen installation dimensions (unit: mm)

B.3.5.2 Cut-out installation description

When you want to build the touch screen into the operation panel of the control cabinet, use the cross screwdriver and metal installation snap-fit. The installation procedure is as follows:

Step 1 Cut a rectangular installation groove on the operation panel of the control cabinet according to the cut-out dimensions, and then insert the touch screen from the front of the operation panel.



Step 2 Insert the metal snap-fits into the back, top and bottom mounting jacks of the touch screen, insert the fastening screws (attached), and then tighten the screws with the cross screwdriver.

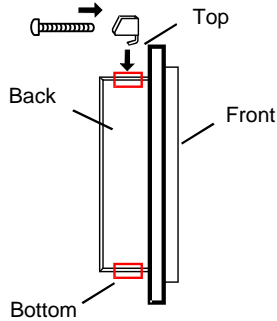

B.4 Filter

Filter model selections for GD300-01A are shown below.

Model	Input filter	Output filter
GD300-01A-7R5G-4-E	FLT-P04032L-B	FLT-L04032L-B
GD300-01A-011G-4-E		
GD300-01A-015G-4-E	FLT-P04045L-B	FLT-L04045L-B
GD300-01A-018G-4-E		
GD300-01A-022G-4-E	FLT-P04065L-B	FLT-L04065L-B
GD300-01A-030G-4-E		
GD300-01A-037G-4-E	FLT-P04100L-B	FLT-L04100L-B
GD300-01A-045G-4-E		
GD300-01A-055G-4-E	FLT-P04150L-B	FLT-L04150L-B
GD300-01A-075G-4-E		
GD300-01A-090G-4-E	FLT-P04240L-B	FLT-L04240L-B
GD300-01A-110G-4-E		
GD300-01A-132G-4-E		
GD300-01A-160G-4-E	FLT-P04400L-B	FLT-L04400L-B
GD300-01A-185G-4-E		
GD300-01A-200G-4-E		
GD300-01A-220G-4-E	FLT-P04600L-B	FLT-L04600L-B
GD300-01A-250G-4-E		
GD300-01A-280G-4-E		
GD300-01A-315G-4-E	FLT-P04800L-B	FLT-L04800L-B
GD300-01A-350G-4-E		
GD300-01A-400G-4-E		
GD300-01A-500G-4-E	FLT-P041000L-B	FLT-L041000L-B

B.5 Reactor

When the distance between the VFD and motor is longer than 50 meters, the parasitic capacitance between the long cable and ground may cause large leakage current, and overcurrent protection of the VFD may be frequently triggered. To prevent this from happening and avoid damage to the motor insulator, compensation must be made by adding an output reactor. When a VFD is used to drive multiple motors, take the total length of the motor cables (that is, sum of the lengths of the motor cables) into account. When the total length is longer than 50 meters, an output reactor must be added on the output side of the VFD. If the distance between the VFD and motor is 50 meters to 100 meters, select the reactor according to the following table. If the distance is longer than 100 meters, contact INVT's technical support technicians.

Table B-8 Reactor model selection

Model	Input reactor	DC reactor	Output reactor
GD300-01A-132G-4-E	ACL2-160-4	DCL2-132-4	OCL2-160-4
GD300-01A-160G-4-E	ACL2-160-4	DCL2-160-4	OCL2-200-4
GD300-01A-185G-4-E	ACL2-200-4	DCL2-220-4	OCL2-200-4
GD300-01A-200G-4-E	ACL2-200-4	DCL2-220-4	OCL2-200-4
GD300-01A-220G-4-E	ACL2-280-4	DCL2-220-4	OCL2-280-4
GD300-01A-250G-4-E	ACL2-280-4	DCL2-280-4	OCL2-280-4
GD300-01A-280G-4-E	ACL2-280-4	DCL2-280-4	OCL2-280-4
GD300-01A-315G-4-E	ACL2-350-4	DCL2-315-4	OCL2-350-4
GD300-01A-350G-4-E	ACL2-350-4	DCL2-400-4	OCL2-350-4
GD300-01A-400G-4-E	Standard configuration	DCL2-400-4	OCL2-400-4
GD300-01A-500G-4-E	Standard configuration	DCL2-500-4	OCL2-500-4

Appendix C Current transformer of the fan

C.1 Current transformer model selection

Power of the cooling fan (kW)	Rated current of cooling fan (A)	Recommended transformation ratio of the transformer
0.75	2	40A/40mA
1.1	2.7	
1.5	3.7	
2.2	5	
3	6.8	
4	8.8	
5.5	11.6	

Note:

1. The fan can sustain tripled overload at a short-time. In order to ensure the fan can be protected by the VFD properly, the current on input side of the current transformer should be more than three times of the rated current of the fan.
2. You can select the transformation ratio of the current transformer. Transformation ratio of 200 or 1000 is recommended.

C.2 Wiring of current transformer of the fan

The transformer should be purchased by the user. The figure below illustrates the wiring precautions for transformer. If the transformer actually used differs from the one shown in the figure below, please consult with the transformer manufacturers.

1. If users adopt 2-phase combined current transformer, please refer to the wiring diagram below.

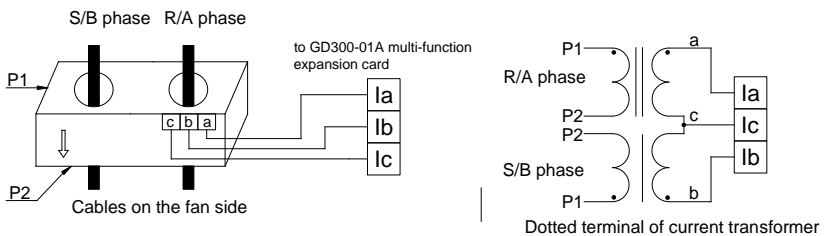

The main circuit cable must go in from P1 and out from P2. The coil a, b and c on output side of the transformer must be connected to la, lb and lc respectively. A and B must correspond to a and b respectively.

2. If users choose single current transformer, refer to the wiring diagram below.

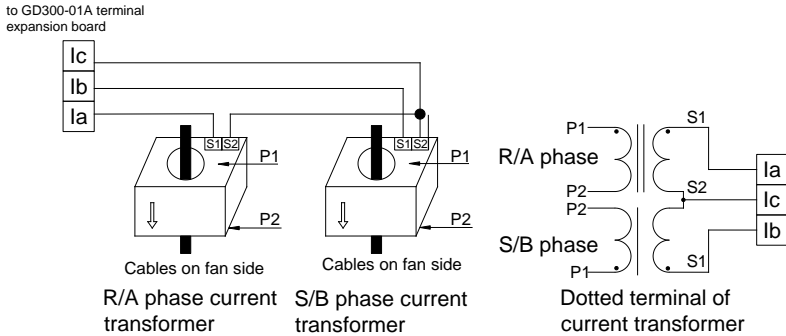

Pay attention to the current direction during wiring. P1 and S1 are dotted terminals, so does P2 and S2, namely the main circuit cable goes in from P1 and out from P2, and the S1 on output side of R/A phase must be connected to la, and S2 to lc. The S1 on output side of S/B phase must be connected to lb, and S2 to lc.

Note:

1. Open circuit is not allowed on output side;
2. Avoid large power and interference during transformer wiring;
3. Wiring of the transformer and terminal expansion board can be carried out only after power off.

C.3 Parameter setup of current transformer of the fan

1. You can select the transformation ratio of the current transformer as needed. Transformation ratio of 200 or 1000 is recommended.
2. After confirming transformer model, input the rated current value of the cooling fan.

Appendix D Communication protocol

D.1 Application mode

The Modbus protocol of this VFD is RTU mode and the network line is RS485.

The interface of RS485 works on semiduplex and its data signal adopts differential transmission mode which is also called balance transmission, too. It uses twisted pairs, one of which is defined as A (+) and the other is defined as B (-). Generally, if the positive electrical level sending between drive A and B is among +2 to +6V, it is logic "1", if the electrical level is among -2V to -6V; it is logic "0".

485+ on the VFD terminal board corresponds to A and 485- to B.

Communication baud rate (P14.01) means the binary bit number transmitted in one second. The unit is bit/s (bps). The higher the baud rate is, the quicker the transmission speed is and the weaker the anti-interference is. If the twisted pairs of 0.56mm (24AWG) is used as the communication cables, the max. transmission distance is as below.

Baud rate (bps)	Max. transmission distance	Baud rate (bps)	Max. transmission distance
2400	1800m	9600	800m
4800	1200m	19200	600m

It is recommended to use shield cables and make the shield layer as the grounding lines during RS485 remote communication.

In the cases with less devices and shorter distance, it is recommended to use 120Ω terminal resistor as the performance will be weakened if the distance increases even though the network can perform well without load resistor.

D.2 RTU command code and communication data

Command code: 03H, read N words (N≤16)

Command code 03H means that if the master read data from the VFD, the data number depends on the "data number" in the command code. The max. number is 16 and the parameter address to be read must be continuous. The length of every data is 2 bytes (one word). The following command format is illustrated in hex (a number with "H" means hex) and one hex number occupies one byte.

This command code is used to read the parameter and working state of the VFD.

Command code: 06H, write one word

This command means the master writes data to the VFD and one command can write one data only. It is used to change the parameter and working mode of the VFD.

Command code: 08H, diagnosis function

Meaning of sub-function codes:

Sub-function code	Description
0000	Return to inquire information data

Definition of data address

The address definition of communication data is used to control VFD operations, obtain VFD state information and set function parameters.

(1) Rules for presentation of function code address

The parameter address occupies 2 bytes with the most significant byte (MSB) in the front and the least significant byte (LSB) in the behind. The ranges of the MSB and LSB are: MSB—00 – ffH; LSB—00 – ffH. The MSB is the group number before the radix point of the function code and the LSB is the number after the radix point, but both the MSB and the LSB should be converted into hex. For example P05.06, the group number before the radix point of the function code is 05, then the MSB of the parameter is 05, the number after the radix point is 06, then the LSB of the parameter is 06, and the function code address is 0506H in hex. Similarly, the parameter address of P10.01 is 0A01H.

(2) Address description of other Modbus functions

The address definition of communication data is used to control VFD operations, obtain VFD state information and set function parameters.

Table D-1 Other function parameters

Function description	Address definition	Data meaning	R/W characteristics
Communication control command	2000H	0001H: Forward running	R/W
		0002H: Reverse running	
		0003H: Forward jogging	
		0004H: Reverse jogging	
		0005H: Stop	
		0006H: Coast to stop (emergency stop)	
		0007H: Fault reset	
		0008H: Jogging stop	
Address of the set value of communication	2001H	The set communication frequency (0–Fmax (unit: 0.01Hz))	R/W
	2002H	PID reference, range (0–1000, 1000 corresponds to 100.0%)	R/W
	2003H	PID feedback, range (0–1000, 1000 corresponds to 100.0%)	R/W
	2004H	The set torque value (-3000–3000, 1000 corresponds to 100.0% of the rated motor current)	R/W
	2005H	The set value of upper limit frequency of	R/W

Function description	Address definition	Data meaning	R/W characteristics
		forward rotating (0–Fmax (unit: 0.01Hz))	
	2006H	The set value of upper limit frequency of reverse rotating (0–Fmax (unit: 0.01Hz))	R/W
	2007H	Upper limit torque of electromotion torque (0–3000, 1000 corresponds to 100.0% of motor current of the VFD)	R/W
	2008H	Upper limit torque of brake torque (0–3000, 1000 corresponds to 100.0% of rated motor current)	R/W
	2009H	Special control command word: Bit0–1: =00: Motor 1 =01: Motor 2 =10: Motor 3 =11: Motor 4 Bit2: =1 Torque control =0: Speed control Bit3: =1 Power consumption cleared to zero =0: Power consumption not cleared to zero Bit4: =1 Pre-excitation =0: Pre-excitation forbidden Bit5: =1 DC brake =0: DC brake forbidden	R/W
	200AH	Virtual input terminal command, range: 0x000–0x1FF	R/W
	200BH	Virtual output terminal command, range: 0x00–0x0F	R/W
	200CH	The set voltage value (used for V/F separation) (0–1000, 1000 corresponds to 100.0% rated motor voltage)	R/W
	200DH	The set value 1 of AO output (-1000–1000, 1000 corresponds to 100.0%)	R/W
	200EH	The set value 2 of AO output (-1000–1000, 1000 corresponds to 100.0%)	R/W
	200FH	BIT0: =1 running time of part 1 cleared to zero; =0: invalid BIT1: =1 running time of part 2 cleared to zero =0: invalid BIT2: =1 running time of part 3 cleared to zero =0: invalid	R/W

Function description	Address definition	Data meaning	R/W characteristics
		BIT3: =1 running time of part 4 cleared to zero =0: invalid BIT4: =1 running time of part 5 cleared to zero =0: invalid BIT5: =1 device running time cleared to zero =0: invalid BIT6: =1 solenoid valve loading =0: solenoid valve unloading	
	2010H	The set maintenance time of part 1; Range: 0–65535	W
	2011H	The set maintenance time of part 2; Range: 0–65535	W
	2012H	The set maintenance time of part 3; Range: 0–65535	W
	2013H	The set maintenance time of part 4; Range: 0–65535	W
	2014H	The set maintenance time of part 5; Range: 0–65535	W
	2015H	Running time of part 1, 0–65535	W
	2016H	Running time of part 2, 0–65535	W
	2017H	Running time of part 3, 0–65535	W
	2018H	Running time of part 4, 0–65535	W
	2019H	Running time of part 5, 0–65535	W
	201AH	Running time of the device: 0–65535	W
	201BH	Start/stop command of power-frequency fan, 0–3	W
VFD state word 1	2100H	0001H: In forward running	R
		0002H: In reverse running	
		0003H: In stopping	
		0004H: In fault	
		0005H: VFD Poff state	
		0006H: VFD pre-exciting state	
VFD state word 2	2101H	Bit0: =0: Not ready to run =1: Ready to run Bi1–2: =00: Motor 1 =01: Motor 2 =10: Motor 3 =11: Motor 4 Bit3: =0: Asynchronous motor =1: Synchronous motor	R

Function description	Address definition	Data meaning	R/W characteristics
		Bit4: =0: Non-overload pre-alarm =1: Overload pre-alarm Bit5– Bit6: =00: Keypad control =01: Terminal control =10: communication control	
VFD fault code	2102H	See fault type	R
VFD identification code	2103H	GD300-01A (optional multi-function expansion card)-----0x0132	R
Running frequency	3000H	Compatible with CHF100A, CHV100 communication address	R
The set frequency	3001H		R
Bus voltage	3002H		R
Output voltage	3003H		R
Output current	3004H		R
Running speed	3005H		R
Output power	3006H		R
Output torque	3007H		R
Closed- loop setting	3008H		R
Closed- loop feedback	3009H		R
Input IO state	300AH		R
Output IO state	300BH		R
Analog input 1	300CH		R
Analog input 2	300DH		R
Analog input 3	300EH		R
Analog input 4	300FH		R
Read high speed pulse 1 input	3010H		R
Read high speed pulse 2 input	3011H		R

Function description	Address definition	Data meaning	R/W characteristics
Read current step number of multi-step speed	3012H		R
External length value	3013H		R
External counting value	3014H		R
The set torque value	3015H		R
VFD identification code	3016H		R
Fault code	5000H		R

Error message response

Table D-2 Error message response and meaning

Code	Name	Meaning
01H	Illegal command	The command from master cannot be executed. The reason maybe: 1. This command is only for new version and this version cannot realize. 2. Slave is in fault state and cannot execute it.
02H	Illegal data address.	Some of the operation addresses are invalid or not allowed to access. Especially the combination of the register and the transmitting bytes are invalid.
03H	Illegal data value	When there are invalid data in the message framed received by slave. Note: This error code does not indicate the data value to write exceed the range, but indicate the message frame is an illegal frame.
04H	Operation failed	The parameter setting in parameter writing is invalid. For example, the function input terminal cannot be set repeatedly.
05H	Password error	The password written to the password check address is not same as the password set by P07.00.
06H	Data frame	In the frame message sent by the upper computer, the length of the digital frame is incorrect or the counting of CRC check bit in RTU is

Code	Name	Meaning
	error	different from the lower computer.
07H	Written not allowed.	It only happen in write command, the reason maybe: 1. The written data exceeds the parameter range. 2. The parameter should not be modified now. 3. The terminal has already been used.
08H	Parameter cannot be modified during running	The modified parameter in the writing of the upper computer cannot be modified during running.
09H	Password protection	When the upper computer is writing or reading and the user password is set without password unlocking, it will report that the system is locked.

The slave uses function code fields and fault addresses to indicate it is a normal response or some error occurs (named as objection response). For normal responses, the slave shows corresponding function codes, digital address or sub-function codes as the response. For objection responses, the slave returns a code which equals the normal code, but the first byte is logic 1.

For example: when the master sends a message to the slave, requiring it to read a group of address data of the VFD function codes, there will be following function codes:

0 0 0 0 0 1 1 (Hex 03H)

For normal responses, the slave responds the same codes, while for objection responses, it will return:

1 0 0 0 0 1 1 (Hex 83H)

Besides the function codes modification for the objection fault, the slave will respond a byte of abnormal code which defines the error reason. When the master receives the response for the objection, in a typical processing, it will send the message again or modify the corresponding command.

Appendix E Common EMC problems and troubleshooting

E.1 Interference problems of meter switches and sensors

Interference phenomena:

The sensor signal (pressure, temperature, displacement, etc.) is collected and displayed via HMI device, the sensor value displayed after VFD starts is wrong, the common phenomena are listed below:

- ✧ Incorrect display of upper limit or lower limit value, such as 999 or -999.
- ✧ The displayed value changes randomly (often occurred to pressure transmitter).
- ✧ The displayed value is stable but huge deviation exists e.g. the displayed temperature value is dozens of centigrade higher than the normal value (often occurred to thermocouple).
- ✧ The signal collected by the sensor does not display directly but acts as feedback signal for drive system operation e.g. the VFD is supposed to decelerate when the air compressor has reached the upper limit pressure, however, the VFD starts to decelerate before upper limit pressure is reached.
- ✧ Various meters connected by VFD analog output (AO) (such as frequency meter, current meter, etc.), the value displayed by these meters after VFD starts is inaccurate.
- ✧ The system adopts proximity switch. The indicator of proximity switch flickers after VFD starts, overturn occurred to output level by mistake.

Solutions:

- ✧ Check and confirm the sensor feedback line is routed with motor cable at a distance of at least 20cm.
- ✧ Check and ensure motor ground line has been connected to PE terminal of the VFD (if motor ground line has been connected to the grounding bar of VFD cabinet, measure with multimeter to confirm that the resistance between grounding bar and PE terminal is less than 1.5Ω).
- ✧ If there are too many interfered meters/sensors, it is recommended to install external C2 filter at the input power side of the VFD.

E.2 485 communication interferences

The 485 communication interference mainly lies in communication delay, out-of-synchronization, disconnection or occasional normal after VFD starts.

Abnormal communication is not always caused by interference, which can be ruled out by below means.

- ✧ Check if circuit break or poor contact occurred to 485 communication bus.
- ✧ Check if both ends of A, B cable of the 485 communication bus are connected reversely.
- ✧ Check if the communication protocol (e.g. baud rate, data bit check, etc.) of the VFD is in consistent with that of the upper PC.

If it is confirmed that the abnormality is caused by interference, rule out the problem cause by below means.

Troubleshooting:

- ✧ The communication cable cannot be routed with motor cable in the same cable tray.
- ✧ In multi-machine application, the connection of communication cables between VFDs should adopt chrysanthemum mode to improve anti-interference ability.
- ✧ In multi-machine application, it is necessary to confirm that the drive capacity of the master is strong enough.
- ✧ For multi-machine connection, both ends should be connected to 120Ω terminal resistors.

Solutions:

- ✧ Check and confirm the motor ground line is connected to PE terminal of the VFD (if motor ground line has been connected to the grounding bar of VFD cabinet, measure with multimeter to confirm that the resistance between grounding bar and PE terminal is less than 1.5Ω);
- ✧ The VFD and motor cannot be common grounded along with the communication upper PC (PLC, HMI, touch screen, etc.). It is recommended to connect the VFD and motor to the power GND, and connect the communication upper PC to the ground pile separately;
- ✧ Try to short connect reference GND terminal of VFD signal to the reference GND terminal of upper PC controller signal to ensure the ground potential of their communication chips is the same;
- ✧ Try to short connect reference GND terminal of VFD signal to the grounding terminal (PE) of the VFD.

E.3 Unstoppable or shimmering indicator caused by coupling of motor cable**Interference phenomena:**

- ✧ Unable to stop

For VFD system whose start/stop is controlled by S terminal, the motor cable and control cable are routed in the same cable tray. After system starts, it cannot stop by S terminal.

- ✧ Shimmering indicator

After VFD starts to run, shimmering, flickering or abnormal noise occurred to below equipment:

- ✧ Relay indicator.
- ✧ Indicator of distribution box.
- ✧ PLC indicator.
- ✧ Indicating buzzer.

Solutions:

- ✧ Check and confirm the abnormal signal cable is routed with motor cable motor cable at a distance of at least 20cm.
- ✧ Connect in parallel the digital input terminal (S) used for start/stop control with other idle digital input terminals. For instance, S1 terminal is used for start/stop control, S4 terminal is idled, then try to short connect S1 terminal with S4 terminal.

E.4 Leakage current and residual current device (RCD)

As the VFD outputs high frequency PWM voltage to drive the motor, the distributed capacitance against the radiator from internal IGBT and between rotor and stator of the motor may cause the VFD to generate high frequency leakage current against the ground. While the RCD is used to detect the power frequency leakage current when grounding fault occurred to electrical circuit, the application of VFD may cause mal-operation of RCD.

How to select RCD:

Due to the specialty of VFD system, it is required that the rated residual operating current should be above 200mA for regular RCDs at all levels, and the VFD must be grounded with proper technics.

As for the setting time of RCD, the time limit of preceding action should be longer than the secondary action and time gap between them should be set to a value larger than 20ms e.g. 1s, 0.5s and 0.2s.

It is recommended to use electromagnetic RCD for the electrical circuit of VFD system. Such RCD carries strong anti-interference capacity to prevent the RCD from being affected by high frequency leakage current.

Electronic RCD	Electromagnetic RCD
Low cost, high sensitivity, small size, vulnerable to voltage fluctuation of the grid and ambient temperature, weak anti-interference capacity	Require the zero sequence current transformer to be quite sensitive, precise and stable, made from permalloy material with high permeability, complicated process and high cost, immune to voltage fluctuation of the grid and ambient temperature., strong anti-interference capacity

Solution to mal-operation of RCD (on the part of VFD)

- a) Try to disassemble the jumper cap in “EMC/J10”.
- b) Try to decrease the carrier frequency to 1.5kHz (P00.14=1.5).
- c) Try to change the modulation mode to “3PH modulation and 2PH modulation” (P8.40=00).

Solution to mal-operation of RCD (on the part of system distribution)

- a) Check and confirm the power cable is not immersed in water.
- b) Check and confirm the cable is not broken or switched over.

- c) Check and confirm if secondary grounding occurred to the null line.
- d) Check and confirm if power cable terminal is in the air switch or the contactor is poorly contacted (loose screws).
- e) Check the single-phase electric equipment and confirm if the ground line is misused as null line.
- f) VFD power cable and motor cable should not be shielded ones.

Leakage protection of motor autotuning:

During motor autotuning, the measurement on differing motor parameters is conducted step by step, in which the first two steps is to measure the resistance of motor stator/rotor while the VFD will output square wave to motor stator winding at 4kHz (default carrier frequency), as leakage current generated by 4kHz carrier frequency against distributed capacitance between motor rotor and stator during charging/discharging is quite obvious, which may cause mal-operation of RCD. If such problem occurred, bypass RCD first and restore after parameter autotuning is completed.

E.5 Problem of charged device shell

The problem mainly lies in that the device shell carries detectable voltage which gives anyone who touches it a feeling of electrical shock, however, when the VFD is powered up without running, the shell will be uncharged (or the voltage it carries is far lower than human body safety voltage).

Solutions:

- a) If there is distribution grounding or ground pile on users' site, ground the shell of VFD cabinet by power GND or ground pile;
- b) If there is no grounding connection on site, it is necessary to electrically connect the motor shell to grounding terminal PE of the VFD and confirm that the jumper in "EMC/J10" of the VFD is short connected.



Service line: 86-755-23535967 E-mail: overseas@invt.com.cn Website: www.invt.com

The products are owned by **Shenzhen INVT Electric Co.,Ltd.**

Two companies are commissioned to manufacture: (For product code, refer to the 2nd/3rd place of S/N on the name plate.)

Shenzhen INVT Electric Co., Ltd. (origin code: 01)

Address: INVT Guangming Technology Building, Songbai Road,
Matian, Guangming District, Shenzhen, China

INVT Power Electronics (Suzhou) Co., Ltd. (origin code: 06)

Address: 1# Kunlun Mountain Road, Science & Technology Town,
Gaoxin District, Suzhou, Jiangsu, China

- | | | | | |
|-------------------------------|--|--------|--------------------------------------|----------------|
| Industrial Automation: | ■ HMI | ■ PLC | ■ VFD | ■ Servo System |
| | ■ Elevator Intelligent Control System | | ■ Rail Transit Traction System | |
| Energy & Power: | ■ UPS | ■ DCIM | ■ Solar Inverter | ■ SVG |
| | ■ New Energy Vehicle Powerstain System | | ■ New Energy Vehicle Charging System | |
| | ■ New Energy Vehicle Motor | | | |



Copyright© INVT.

Manual information may be subject to change without prior notice.

202011 (V1.0)